

EUROMOLD®

INTERFACE A
MEDIUM VOLTAGE SEPARABLE
CONNECTORS AND BUSHINGS

CATALOGUE 2022



NEXANS NETWORK SOLUTIONS DIV. EUROMOLD

COMPANY PRESENTATION



EUROMOLD

Nexans is the leading European specialised designer, manufacturer and distributor of prefabricated cable accessories for medium voltage energy distribution. Under its tradename Euromold, it provides a complete range of accessories for underground cables: premoulded EPDM rubber connectors for cables and epoxy bushings for transformers and switchgear, as well as a large range of cold-shrinkable terminations and joints from 12 to 42 kV.

Nexans division Euromold is also the manufacturer of electrical components for the high voltage accessories of the Nexans group.

ISO 9001 Certificate

Since 1992, Nexans' commitment to quality is demonstrated by its ISO 9001 certification. We are also certified in the important sectors of environmental protection and occupational safety.

International standards

All our products meet the International standards like CENELEC HD 629.1, CENELEC EN 50180, IEC 60137, IEC 60502-4... or country specifications. Official certificates, CESI, KEMA, ATEX... prove the conformity of our products. Long duration tests of existing or new products are continuously performed in our test fields.

Laboratory accreditation

Since June 2000, Nexans' independent ELAB laboratory obtained the BELAC accreditation no.144-TEST conform with the European standards for laboratories ISO 17025 for electrical testing of low and medium voltage cable accessories according to the international standards EN 50393, IEC 60502-4, IEC 61442 and HD 629.



While every care is taken to ensure that the information contained in this publication is correct, no legal responsibility can be accepted for any inaccuracy. Nexans Network Solutions N.V. - Div. Euromold reserves the right to alter or modify the characteristics of its products described in this catalogue as standards and technology evolve.

SEPARABLE CONNECTORS

INTERFACE A

TABLE OF CONTENTS

200LR - elbow connector
200SR - straight connector
151SP - straight plug
156SA - surge arrester
180AR-1 /-2 /-3 and 180AR-1-G /-3-G - equipment bushings
180A-24P-O - in-air bushing
PITO-E - plug-in termination
Accessories
Bail restraints
Possible arrangements

INTERFACE A1

Dimensions according to European
CENELEC EN 50180 and 50181
(in mm).

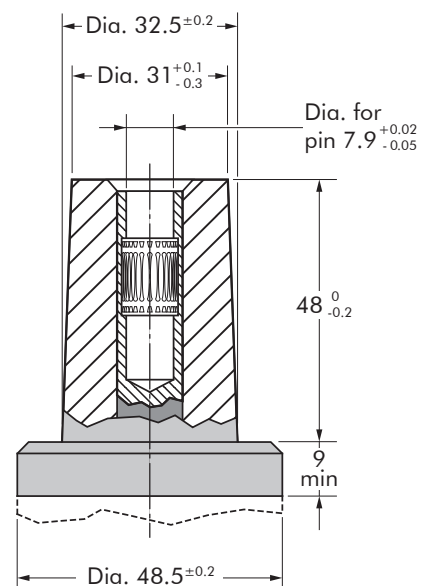



CONNECTING POSSIBILITIES

BUSHINGS / ACCESSORIES / CONNECTOR

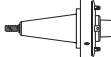
Equipment interface 

(K)180AR-1(-G),-2 & -3(-G)
Equipment bushing 

180A-24P-O
In-air bushing 

(K)150S 

(K)200T
Tee connector 

(K)200X
Cross connector 

(K)150DP
Dead-end plug 

(K)151SOP
Stand-off plug 

250GP
Earthing plug 

(K)400RTPA
Reducing tap plug 

(K)676RTPA
Reducing tap plug 

CONNECTION

dead-ending of equipment

two cables to equipment

three cables to equipment

one line to equipment

one cable to equipment

in-line junction

in-line junction + tap-off

in-line junction + 2 tap-offs

cable isolation

cable earthing

tap-off 630/250 A

tap-off 1250/250 A

CONNECTORS / ACCESSORIES

(K)150DR
Dead-end receptacle 

(K)200T
Tee connector 

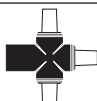
(K)200X
Cross connector 

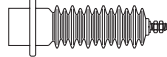
PITO-E
Plug-in termination 

(K)200SR
Straight connector 

(K)200LR
Elbow connector 

156SA
Surge arrester 

(K)200SR
Straight connector 

(K)200LR
Elbow connector 

(K)200T
Tee connector 

(K)200X
Cross connector 

(K)150DR
Dead-end receptacle 

(K)151SP
Straight plug 

disconnectable joint

in-line junction + tap-off

in-line junction + 2 tap-offs

cable isolation

APPLICATION

Separable elbow connector designed to connect polymeric insulated cable to equipment (transformers, switchgear, motors...).

TECHNICAL CHARACTERISTICS

- A thick conductive EPDM jacket provides a total safe to touch screen.
- Each separable connector is tested for AC withstand and partial discharge prior to leaving the factory.



DESIGN

Separable connector comprising:

1. Conductive EPDM insert.
2. Conductive EPDM jacket.
3. Insulating EPDM layer.
4. Type A interface as described by CENELEC EN 50180 and 50181.
5. Conductor contact.
6. Earthing lead.
7. Cable reducer.

The screen break design enables cable outer sheath testing without removing or dismantling the connector.

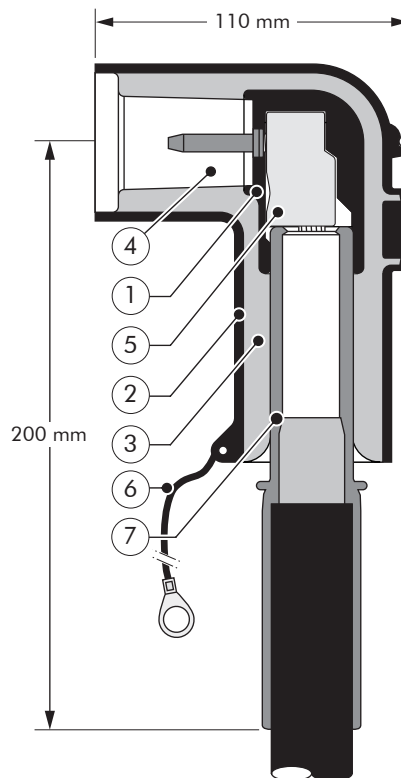

6/10 (12) kV
6.35/11 (12) kV
8.7/15 (17.5) kV
12/20 (24) kV
12.7/22 (24) kV

Up to 24 kV
250 A

EUROMOLD®

SPECIFICATIONS AND STANDARDS

The 200LR separable connector meets the requirements of CENELEC HD 629.1.

Separable connector type	Current I _r (A)	Voltage U _m (kV)	Conductor sizes (mm ²)		Diameter over insulation (mm)	
			min	max	min	max
K200LR-12	250	12 17.5	25 25	95 50	13.0	21.0
K200LR-16	250	17.5 24	50 25	95 95	17.5	25.0

02/2022

KIT CONTENTS

The complete K200LR elbow connector kit comprises 3x the following components:

The kit also comprises silicone grease, water sealing mastic, gloves, wipers, adhesive tape and installation instructions.

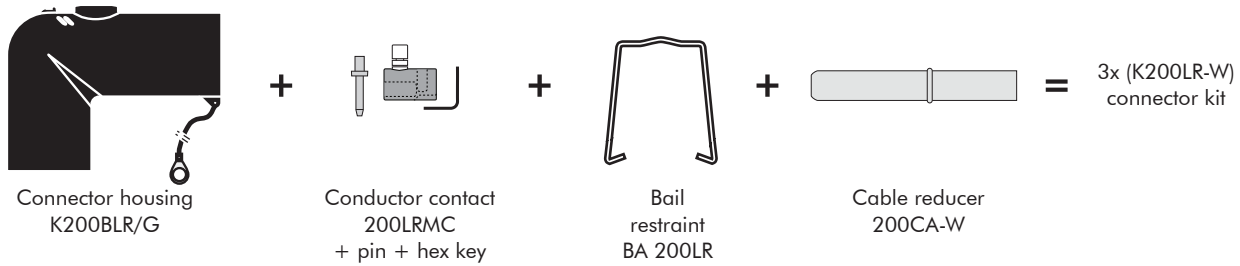

ORDERING INSTRUCTIONS

To order a kit of 3 elbow connectors, specify the type:

- for 12 kV applications: 3x (K200LR-12).
- for 17.5 kV applications: 3x (K200LR-12) for 25 up to 50 mm²
3x (K200LR-16) for 50 up to 95 mm².
- for 24 kV applications: 3x (K200LR-16).

EXAMPLE:

The cable is 24 kV, 50 mm² compact stranded aluminium with a diameter over core insulation of 20.5 mm and copper screen wires.

Order 3x (K200LR-16) elbow connector kit.

OPTIONS

VOLTAGE DETECTION POINT

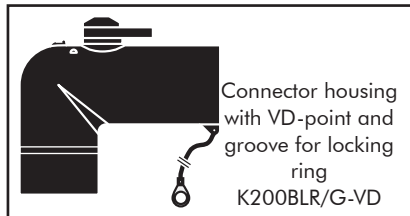

A version with a capacitive voltage divider (for voltage detection) and pre-moulded groove (for locking ring installation) is also available: add -VD to the specified type.

LARGER CONDUCTOR SIZES

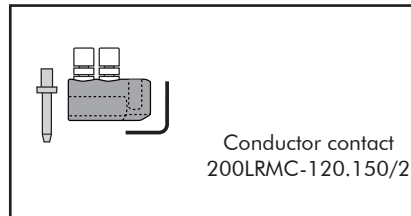

A version for larger conductor sizes (120 and 150 mm²) is also available.

Specify connector type	Current I _r (A)	Voltage U _m (kV)	Conductor sizes (mm ²)	Diameter over insulation
3x (K200LR-16-120.150)	250	12	120-150	17.5-25.0
3x (K200LR-19-120.150)	250	17.5-24	120-150	21.5-28.5

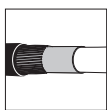

For use with copper wire screened cables. No earthing device is necessary.

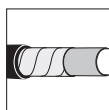

For use with copper tape screened cables. Add -CT to order.

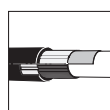

For use with Alupe or C 33-226 cables. Add -MT345 to order.



For use with other cable types. Please contact our representative.



All kits are suitable for use indoor and outdoor.



PEP eco passport available

APPLICATION

Separable straight connector designed to connect polymeric insulated cable to equipment (transformers, switchgear, motors...).

TECHNICAL CHARACTERISTICS

- A thick conductive EPDM jacket provides a total safe to touch screen.
- Each separable connector is tested for AC withstand and partial discharge prior to leaving the factory.



DESIGN

Separable connector comprising:

1. Conductive EPDM insert.
2. Conductive EPDM jacket.
3. Insulating EPDM layer.
4. Type A interface as described by CENELEC EN 50180 and 50181.
5. Conductor contact.
6. Earthing lead.
7. Cable reducer.

The screen break design enables cable outer sheath testing without removing or dismantling the connector.

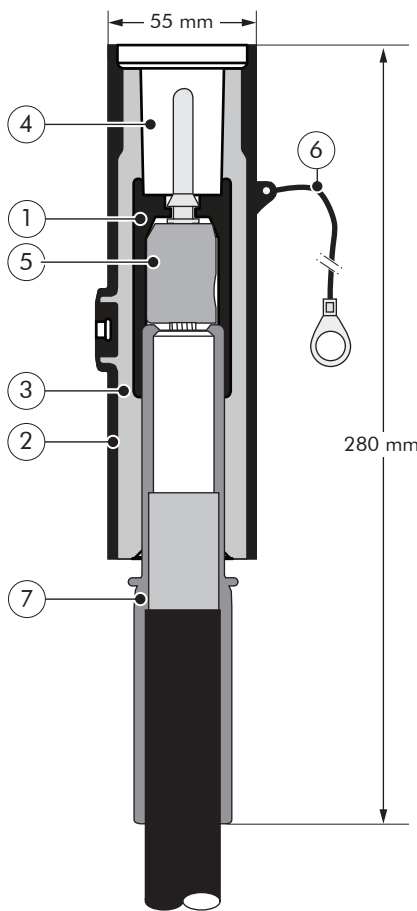

6/10 (12) kV
6.35/11 (12) kV
8.7/15 (17.5) kV
12/20 (24) kV
12.7/22 (24) kV

Up to 24 kV
250 A

EUROMOLD®

SPECIFICATIONS AND STANDARDS

The 200SR separable connector meets the requirements of CENELEC HD 629.1.

Separable connector type	Current I _r (A)	Voltage U _m (kV)	Conductor sizes (mm ²)		Diameter over insulation (mm)	
			min	max	min	max
K200SR-12	250	12 17.5	25 25	95 50	13.0	21.0
K200SR-16	250	17.5 24	50 25	95 95	17.5	25.0

KIT CONTENTS

The complete K200SR straight connector kit comprises 3x the following components:

The kit also comprises silicone grease, water sealing mastic, gloves, wipers, adhesive tape and installation instructions.

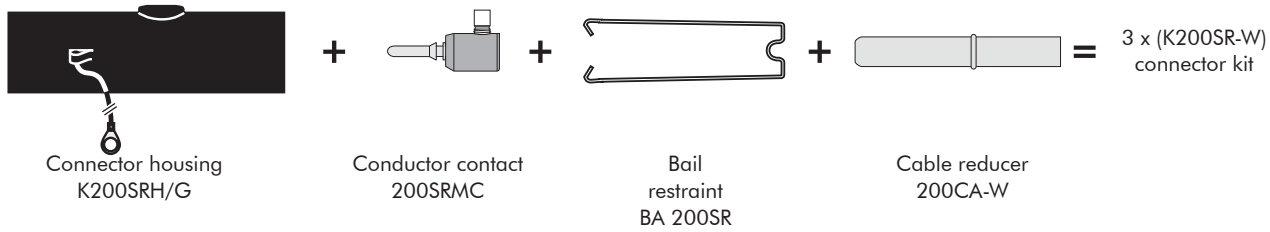

ORDERING INSTRUCTIONS

To order a kit of 3 straight connectors, specify the type:

- for 12 kV applications: 3x (K200SR-12).
- for 17.5 kV applications: 3x (K200SR-12) for 25 up to 50 mm²
3x (K200SR-16) for 50 up to 95 mm².
- for 24 kV applications: 3x (K200SR-16).

EXAMPLE:

The cable is 24 kV, 50 mm² compact stranded aluminium with a diameter over core insulation of 20.5 mm and copper screen wires.

Order 3x (K200SR-16) straight connector kit.

OPTIONS

VOLTAGE DETECTION POINT

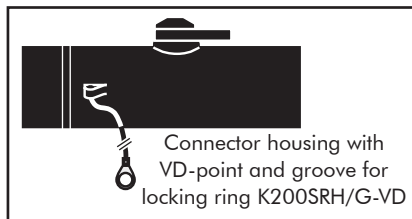

A version with a capacitive voltage divider (for voltage detection) and pre-moulded groove (for locking ring installation) is also available: add -VD to the specified type.

LARGER CONDUCTOR SIZES

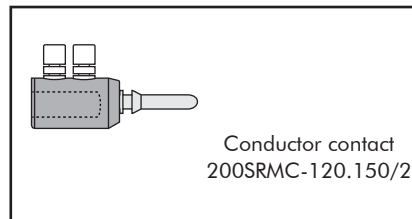

A version for larger conductor sizes (120 and 150 mm²) is also available.

Specify connector type	Current I _r (A)	Voltage U _m (kV)	Conductor sizes (mm ²)	Diameter over insulation
3x (K200SR-16-120.150)	250	12	120-150	17.5-25.0
3x (K200SR-19-120.150)	250	17.5-24	120-150	21.5-28.5

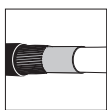

For use with copper wire screened cables. No earthing device is necessary.

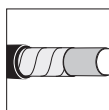

For use with copper tape screened cables. Add -CT to order.

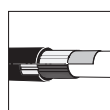

For use with Alupe or C 33-226 cables. Add -MT345 to order.



For use with other cable types. Please contact our representative.



All kits are suitable for use indoor and outdoor.



PEP eco passport available

APPLICATION

Separable straight plug designed to connect polymeric insulated cable to cable.

Mates with the elbow, straight and branch joint connectors.

DESIGN

Separable connector comprising:

1. Conductive EPDM insert.
2. Conductive EPDM jacket.
3. Insulating EPDM layer moulded between the insert and the jacket.
4. Type A interface as described by CENELEC EN 50180 and 50181.
5. Conductor contact.

TECHNICAL CHARACTERISTICS

- The thick conductive EPDM jacket provides a total safe to touch screen which ensures safety for personnel.
- Each straight plug is tested for AC withstand and partial discharge prior to leaving the factory.

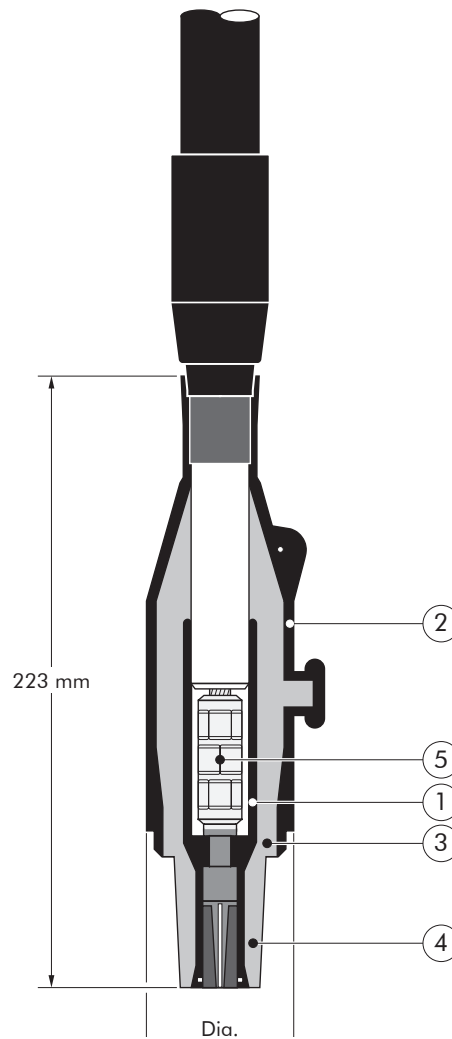

6/10 (12) kV
6.35/11 (12) kV
8.7/15 (17.5) kV
12/20 (24) kV
12.7/22 (24) kV

Up to 24 kV - 200 A

EUROMOLD®

Separable plug type	Voltage U_m (kV)	Current I_r (A)	Conductor sizes (mm ²)	
			min	max
151SP	12	200	16	95
K151SP	24	200	16	95

02/2022

KIT CONTENTS

The complete (K)151SP straight plug kit comprises the following components:

The kit also comprises silicone grease, wipers, installation instructions and crimp chart.

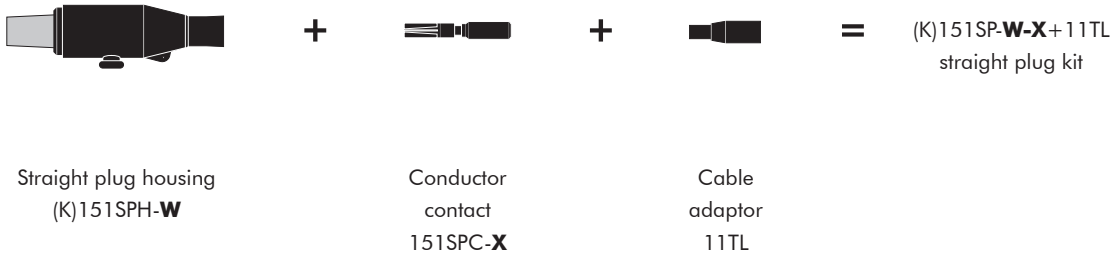

ORDERING INSTRUCTIONS

Select the part number which gives the best centring to the cable core insulation diameter and substitute **X** using table X, according to the conductor size and type.
Add a 'K' for use up to 24 kV.

TABLE W

Ordering part number	Dia. over core insulation (mm)	
	min	max
151SP-A- X +11TL-FA/FAB	14.6	18.7
151SP-B- X +11TL-FB/FG	17.2	21.2
151SP-B- X +11TL-GA/GAB	19.7	23.0
151SP-C- X +11TL-GB/GH	22.2	26.4

EXAMPLE:

The copper wire screened cable is 12 kV, 50 mm² stranded aluminium with a diameter over core insulation of 16.9 mm.
Order a 151SP-A-50(K)M-12-2+11TL-FA/FAB straight plug kit.

TABLE X

Conductor sizes (mm ²)	Aluminium		Copper
	DIN hexagonal	Deep indent	DIN hexagonal
16	-	-	16(K)M-11-2
25	25(K)M-12-2	25KM-12-1	25(K)M-11-2
35	35(K)M-12-2	35KM-12-1	35(K)M-11-2
50	50(K)M-12-2	50(K)M-12-1	50(K)M-11-2
70	70(K)M-12-2	70(K)M-12-1	70(K)M-11-2
95	95(K)M-12-2	95(K)M-12-1	95(K)M-11-2

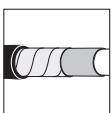

For use with copper tape screened cables.
Order: Kit MT.

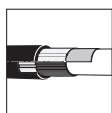

For use with Alupe or C 33-226 cables.
Please contact our representative.



For use with other cable types.
Please contact our representative.

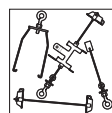

For adapted bail restraints:
see "Other Bail restraints" at the back of this catalogue.



For outdoor applications.
Order: +MWS.



Components can be ordered individually.

156SA

INTERFACE A SURGE ARRESTER

APPLICATION

Surge arrester designed to protect 12 and 24 kV class components, including transformers, equipment, cable and accessories from high voltage surges resulting from lightning or switching.

TECHNICAL CHARACTERISTICS

- This surge arrester is a metal oxide varistor surge arrester in an elbow configuration.
- Each arrester is tested for AC withstand and partial discharge prior to leaving the factory.



DESIGN

Surge arrester comprising:

1. Bail restraint.
2. Conductive EPDM insert.
3. Type A - 250 A interface as described by CENELEC EN 50180 and 50181.
4. Pin contact.
5. Contact disc.
6. Copper shunt.
7. Metal oxide valve elements.
8. Aluminium spacer.
9. Steel cap.
10. Earth connection.
11. Insulating EPDM layer moulded between the insert and the jacket.
12. Conductive EPDM jacket.

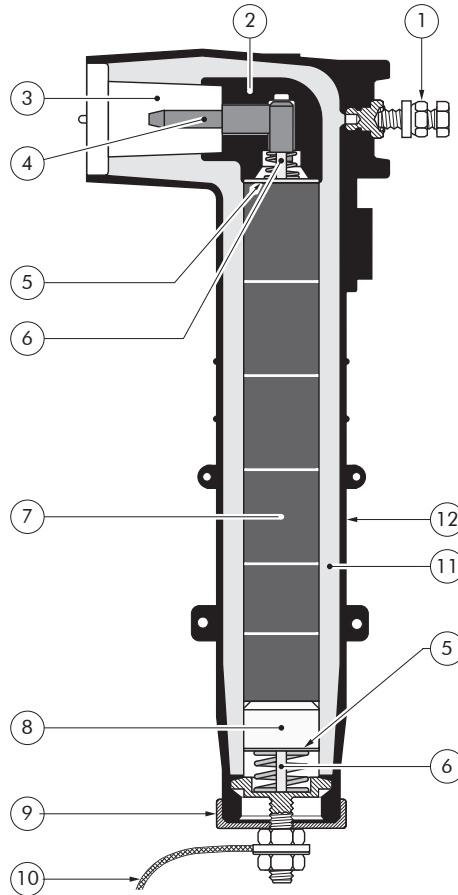

6/10 (12) kV
6.35/11 (12) kV
8.7/15 (17.5) kV
12/20 (24) kV
12.7/22 (24) kV

Up to 24 kV

EUROMOLD®

Surge arrester type	Nominal discharge current I_n (kA)	Rated voltage U_r (kV)	Max continuous operating voltage U_c (kV)	Steep current residual voltage @ 5 kA [1/20 μ s] (kV)	Lightning current residual voltage @ 5 kA [8/20 μ s] (kV)	High current impulse withstand (kA)
156SA-12	5	15	12.5	62.5	54.5	40
156SA-15	5	19	15.5	77.0	69.0	40
156SA-18	5	22	18.0	87.0	79.0	40
156SA-21	5	26	21.0	101.5	93.5	40
156SA-24	5	30	24.5	116.5	108.5	40

02/2022

TYPICAL APPLICATION AND DIMENSIONS

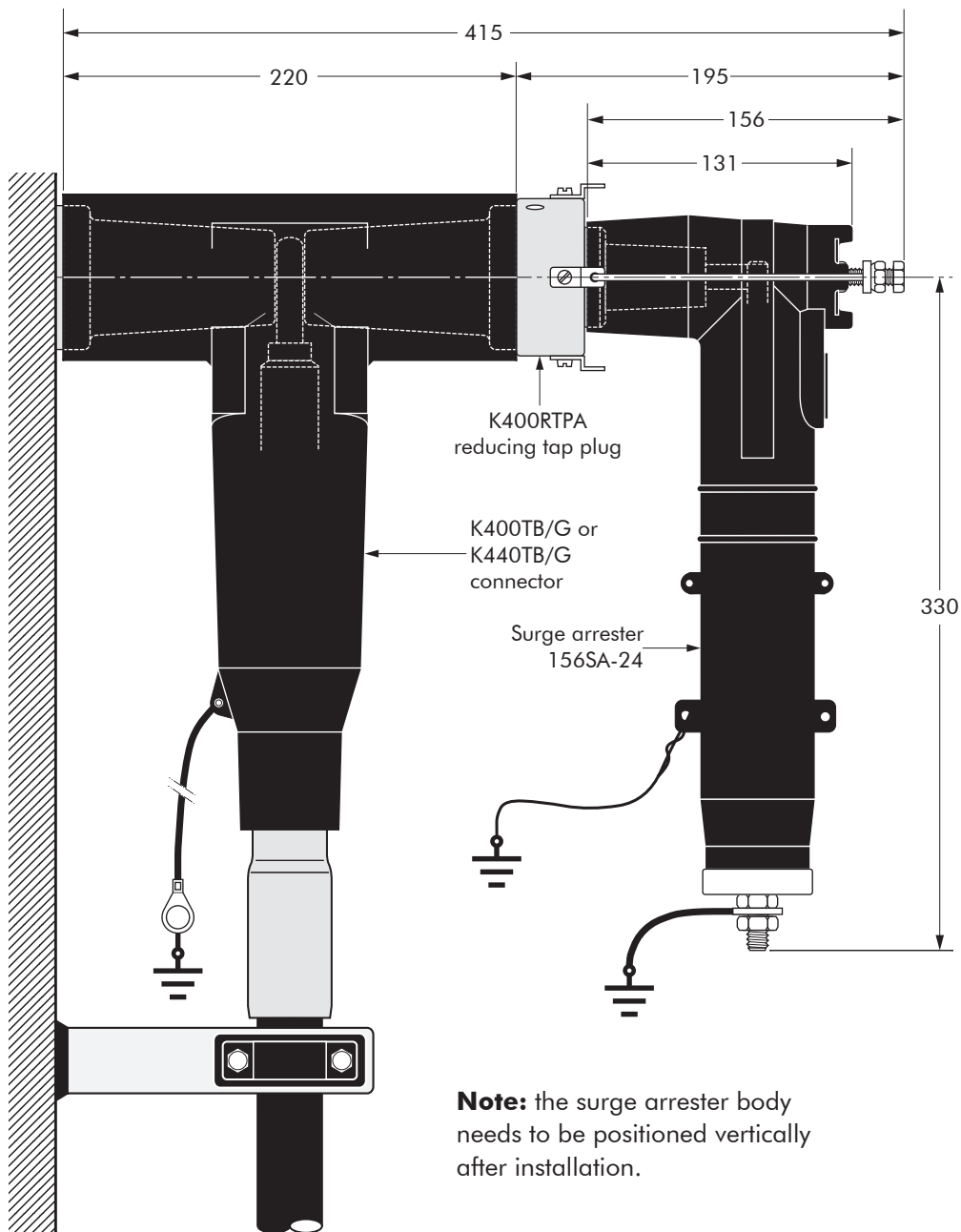

In mm.

ORDERING INSTRUCTIONS

To order the surge arrester, specify the surge arrester type, as described on previous page.

EXAMPLE:

For a maximum continuous operating voltage (r.m.s.) of 21 kV. Order a 156SA-21 surge arrester.

180AR-1/180AR-2/180AR-3

INTERFACE A1 EQUIPMENT BUSHINGS

APPLICATION

For use in equipment insulated with oil fluid, typically for transformers, switchgear, capacitors...

TECHNICAL CHARACTERISTICS

Each bushing is tested for AC withstand and partial discharge prior to leaving the factory.

DESIGN

- The equipment bushings are moulded epoxy insulated parts in accordance with CENELEC EN 50180.
The 180AR-2 bushing has a length B outside this standard.
- The standard bushings, (K)180AR-1 /-2 /-3, are equipped with 6 tabs for the bail restraint.
- The (K)180AR-1-G and (K)180AR-3-G are equipped with 4 tabs and 2 threaded inserts M6 (-G version).

ORDERING INSTRUCTIONS

To order the equipment bushing, specify the type.
The bushings are supplied with an earth jumper (/J) or an earth plate (/GS). This earth connection must be specified when ordering.
E.g. K180AR-1/J.

SPECIFICATIONS AND STANDARDS

The plug-in type equipment bushings 180AR-... meet the requirements of CENELEC EN 50180 and IEC 60137.



Type 180AR-1 /-2 /-3

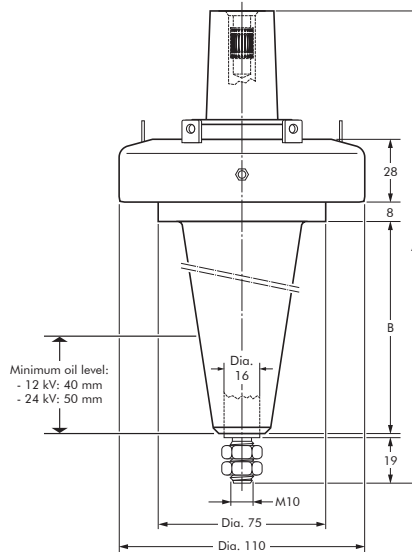

Type 180AR-1-G /-3-G

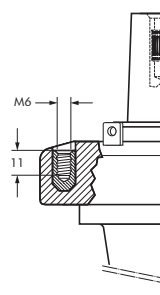

6/10 (12) kV
6.35/11 (12) kV
8.7/15 (17.5) kV
12/20 (24) kV
12.7/22 (24) kV

Up to 24 kV - 250 A

EUROMOLD®

In mm.

Equipment bushing type	Voltage Um (kV)	Current Ir (A)	Dimensions (mm)	
			A	B
180AR-1	12	250	222	106
K180AR-1	24	250	222	106
180AR-2	12	250	284	168
K180AR-2	24	250	284	168
180AR-3	12	250	171	55
K180AR-3	24	250	171	55

02/2022

FIXINGS FOR EQUIPMENT BUSHINGS

180AR-1/GS
180AR-1-G/GS
180AR-2/GS
180AR-3/GS AND
180AR-3-G/GS BUSHINGS

180AR-1/J
180AR-1-G/J
180AR-2/J
180AR-3/J AND
180AR-3-G/J BUSHINGS

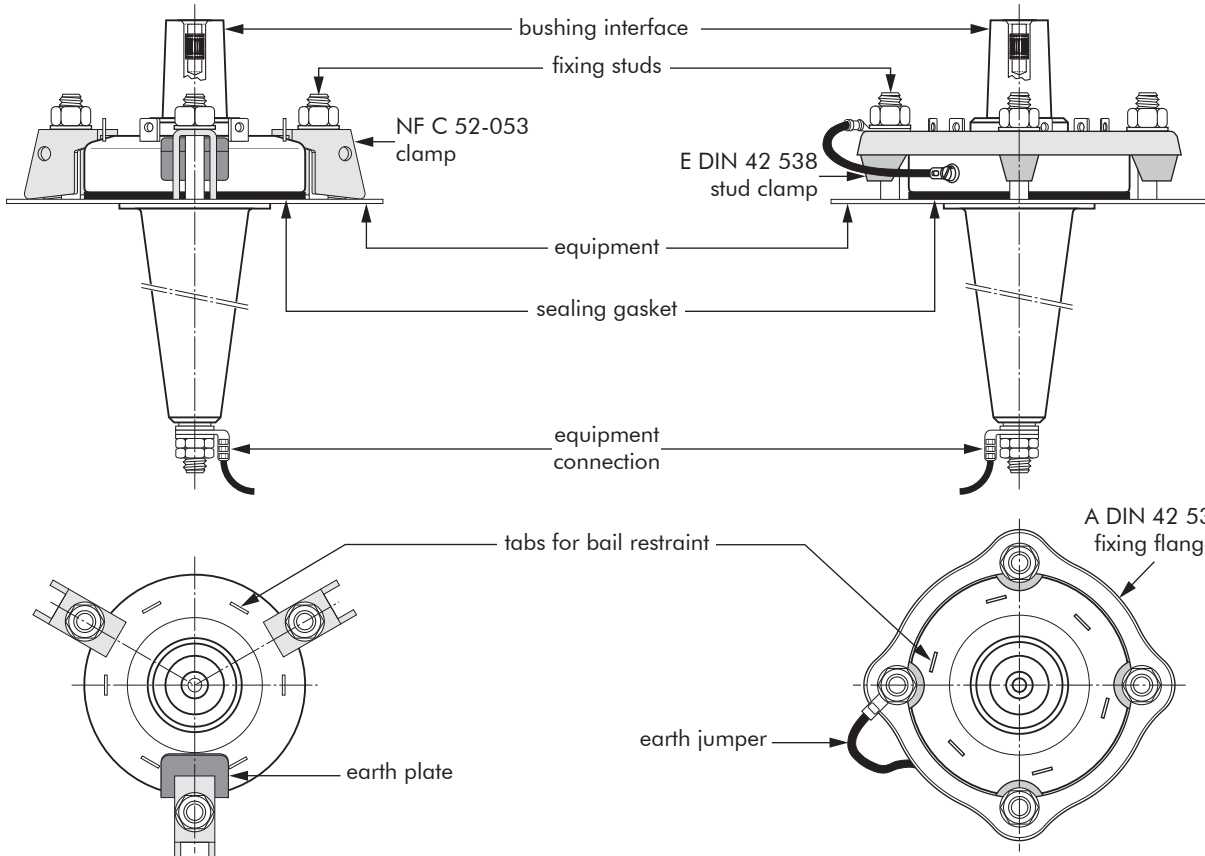

BUSHING CLAMPING KIT

To order the bushing clamping kit, according to NF C 52-053 standards, simply specify: KBC – NFC 52-053 /200 SERIES.
Contents: - 3 x claw clamp NF
- 1 x sealing gasket.

BUSHING CLAMPING KIT

To order the bushing clamping kit, according to DIN 42 538 standards, simply specify: KBC - RING CLAMP 1.
Contents: - 1 x fixing flange A
- 4 x stud clamp E
- 1 x sealing gasket.

FIXING DIMENSIONS STANDARDS NF C 52-053

French standards.

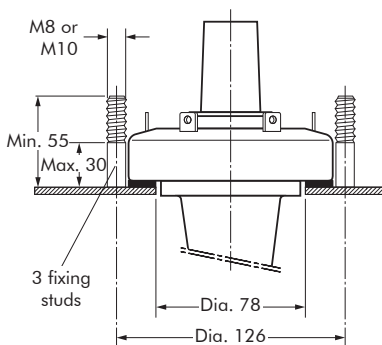

FIXING DIMENSIONS STANDARDS DIN 42 538

German standards.

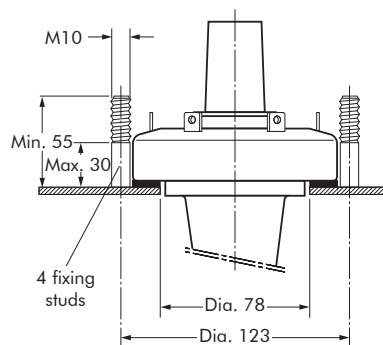

In mm.

180A-24P-O

INTERFACE A1 IN-AIR BUSHING

APPLICATION

For use in equipment insulated with air, typically for dry type transformers, motors, switchgear, capacitors...

TECHNICAL CHARACTERISTICS

Each bushing is tested for AC withstand and partial discharge prior to leaving the factory.

SPECIFICATIONS AND STANDARDS

The plug-in type equipment bushings 180A-24P-O are moulded epoxy insulated parts and meet the requirements of CENELEC EN 50181, IEC 60071 and IEC 60137.

ORDERING INSTRUCTIONS

To order the equipment bushing, specify the type.
The bushings are supplied with an earth jumper.
To include the ring clamp, add:
• /B, if per British standards
• /D, if per German standards
• /F, if per French standards.
E.g. 180A-24P-O/F.

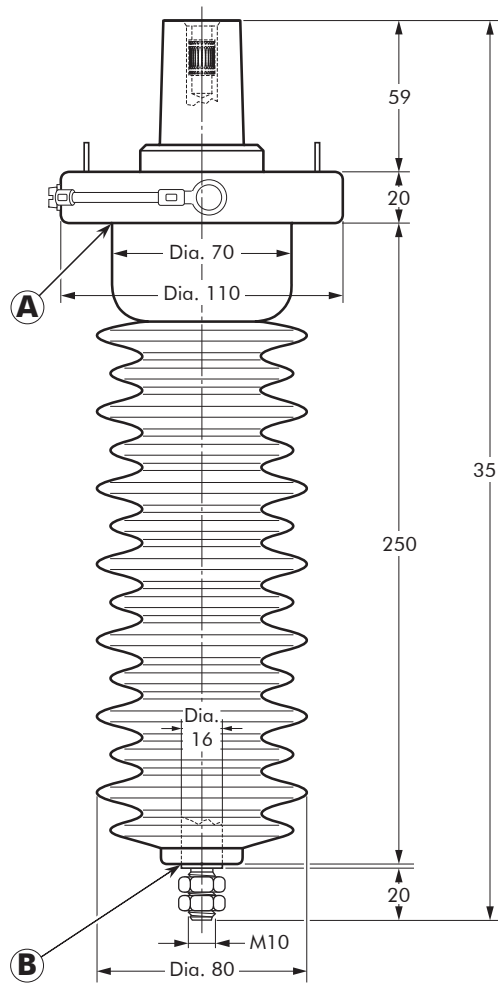

In mm.

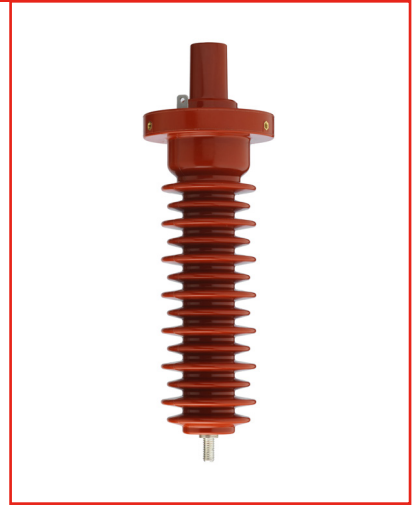

6/10 (12) kV
6.35/11 (12) kV
8.7/15 (17.5) kV
12/20 (24) kV
12.7/22 (24) kV

Up to 24 kV - 250 A

EUROMOLD®

Equipment bushing type	Voltage U_m (kV)	Current I_r (A)	Creepage distance A-B (mm)
180A-24P-O	12	250	630
180A-24P-O	24	250	630

02/2022

FIXINGS FOR EQUIPMENT BUSHINGS

180A-24P-O IN-AIR BUSHING

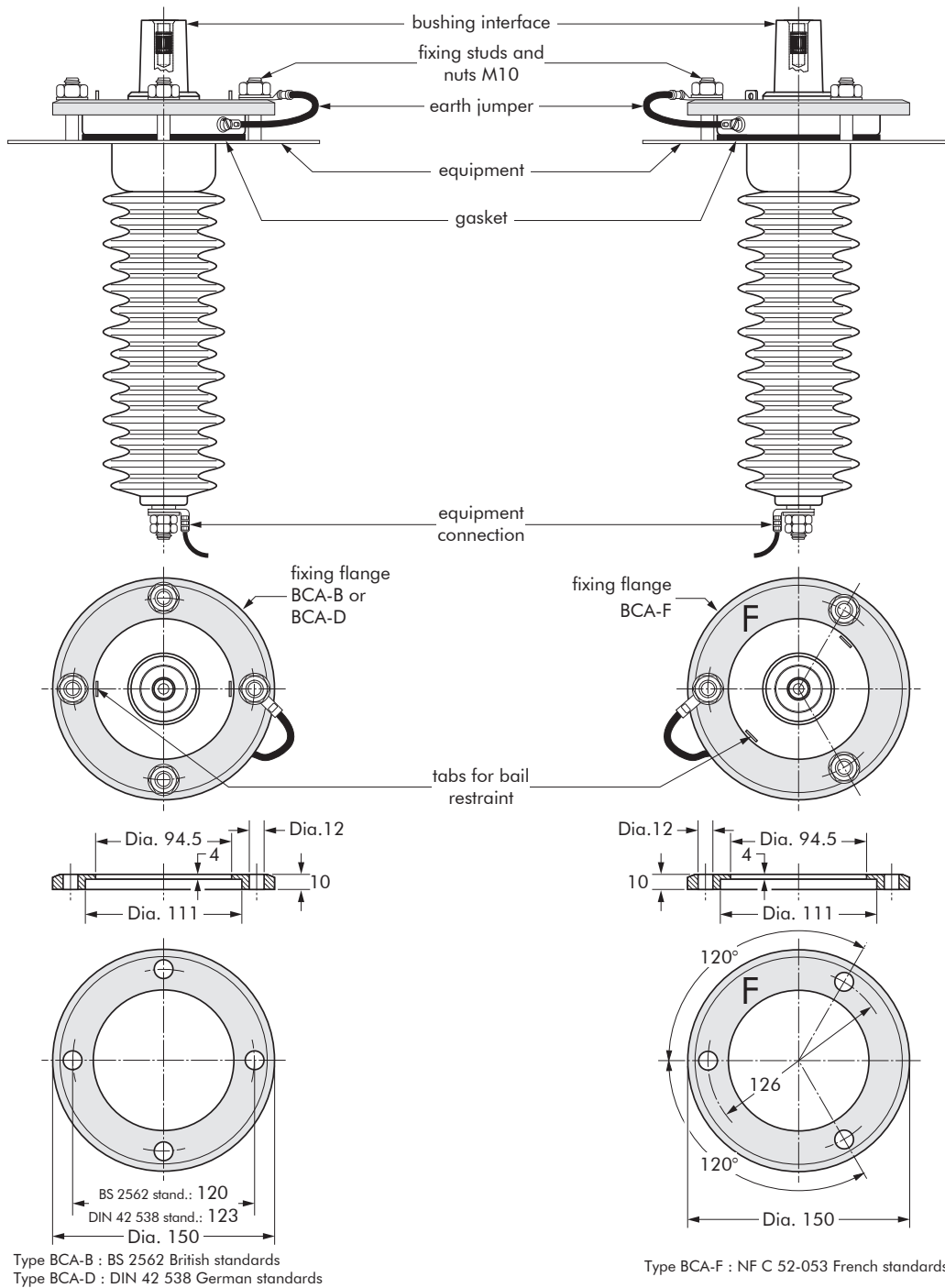

FIXING DIMENSIONS STANDARDS DIN 42 538

German standards.

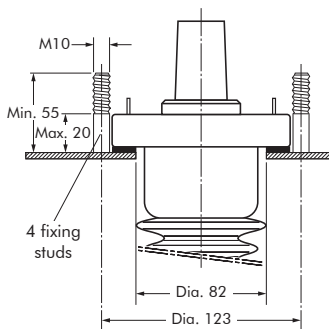

FIXING DIMENSIONS STANDARDS NF C 52-053

French standards.

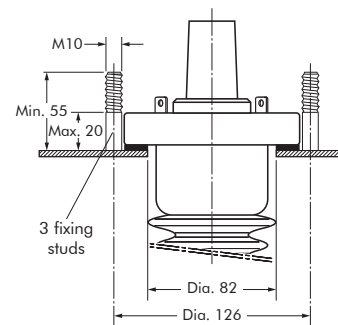

In mm.

APPLICATION

- Separable termination designed to connect overhead lines or bus bars to equipment.
- Is suitable for indoor and outdoor use for medium polluted atmosphere.

DESIGN

The plug-in termination is a moulded epoxy insulated part. It meets the type A - 250 A interface as described in CENELEC EN 50180 and 50181.

SPECIFICATIONS AND STANDARDS

The separable termination PITO-E meets the requirements of IEC 60137.

ORDERING INSTRUCTIONS

To order the plug-in termination for 12 or 24 kV, specify PITO-E. The kit includes the bail restraint (for fixing onto the bushing) and 2 brass nuts (for top connection).

TECHNICAL CHARACTERISTICS

Each plug-in termination is tested for AC withstand prior to leaving the factory.

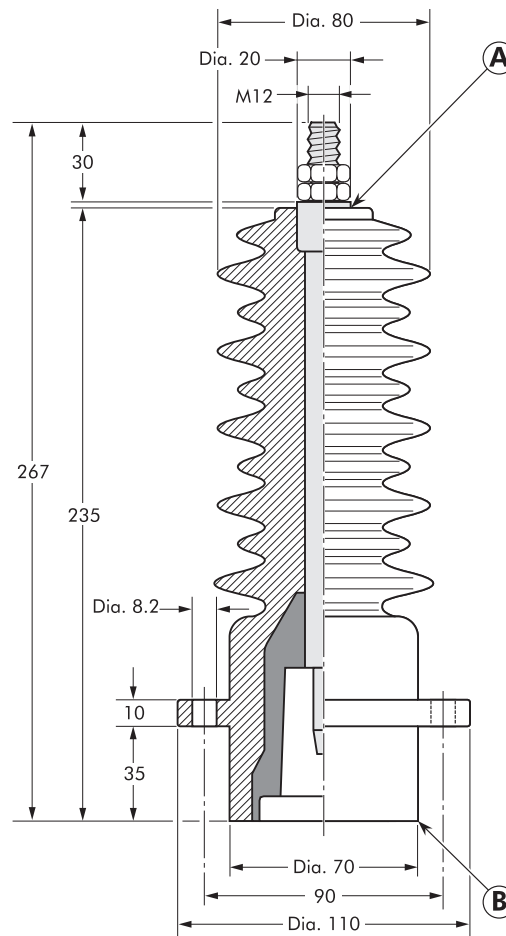

6/10 (12) kV
 6.35/11 (12) kV
 8.7/15 (17.5) kV
 12/20 (24) kV
 12.7/22 (24) kV

Up to 24 kV - 250 A

EUROMOLD®

In mm.

Plug-in termination type	Voltage U_r (kV)	Current I_r (A)	Creepage distance A-B (mm)
PITO-E	12	250	510
PITO-E	24	250	510

APPLICATION

For use with connectors and bushings with an interface A as described by CENELEC EN 50180 and 50181.

TECHNICAL CHARACTERISTICS

All these products, except the earthing plug, are tested for AC withstand and partial discharge prior to leaving the factory.

6/10 (12) kV
6.35/11 (12) kV
8.7/15 (17.5) kV
12/20 (24) kV
12.7/22 (24) kV

Up to 24 kV

EUROMOLD®

150DR DEAD-END RECEPTACLE

Fits over a bushing with a type A interface to provide 'dead-end' facility.

Renders the assembly watertight.



ORDERING INSTRUCTIONS

Order
150DR for 12 kV or
K150DR for 24 kV
applications.
The dead-end receptacle can
be supplied with an earth lead.
Order: -/G. E.g. K150DR/G.

150DP DEAD-END PLUG

Plugs into connectors or receptacles to provide 'dead-end' facility.

Renders the assembly watertight.



ORDERING INSTRUCTIONS

Order
150DP for 12 kV or
K150DP for 24 kV
applications.

151SOP STAND-OFF PLUG

Is designed to support and 'dead-end' connectors with a type A interface when removed from equipment.

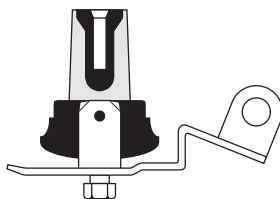

ORDERING INSTRUCTIONS

Order
151SOP for 12 kV or
K151SOP for 24 kV
applications.

250GP EARTHING PLUG

Is designed to support and earth connectors with a type A interface when removed from equipment.

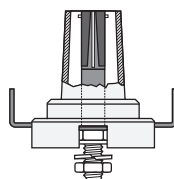

ORDERING INSTRUCTIONS

Order
250GP for 12 kV or 24 kV
applications.

200T SEPARABLE TEE CONNECTOR

Is designed to connect three cables of the same or varying sizes or two cables to equipment.
For an adapted bail, please refer to the catalogue or contact our representative.

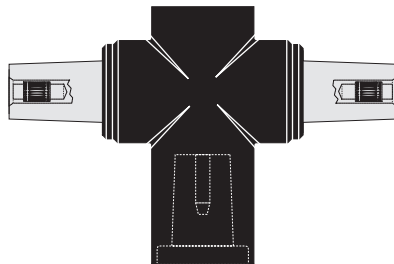

ORDERING INSTRUCTIONS

Order
200T for 12 kV or
K200T for 24 kV
applications.

200X SEPARABLE CROSS CONNECTOR

Is designed to connect four cables of the same or varying sizes or three cables to equipment.
For an adapted bail, please refer to the catalogue or contact our representative.

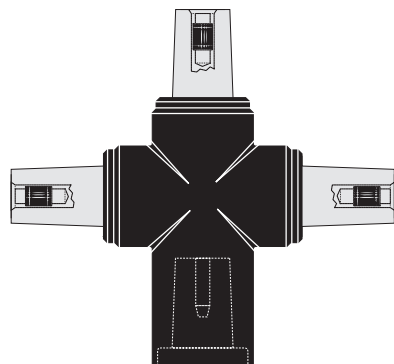

ORDERING INSTRUCTIONS

Order
200X for 12 kV or
K200X for 24 kV
applications.

K150S IN-LINE JUNCTION

Is designed to connect two cables of the same or varying sizes.
For an adapted bail, please refer to the catalogue or contact our representative.



ORDERING INSTRUCTIONS

Order
K150S for 12 kV or 24 kV
applications.

1501J3-U-8 THREE-WAY JUNCTION

Provides a flexible means of connecting two or three cables of the same or varying sizes.
For an adapted bail, please refer to the catalogue or contact our representative.

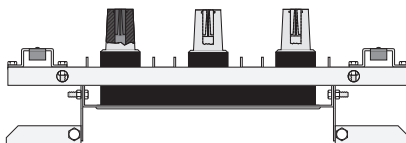

ORDERING INSTRUCTIONS

Order
1501J3-U-8 for 12 kV or
K1501J3-U-8 for 24 kV
applications.

KIT MT EARTHING KIT FOR COPPER TAPE SCREENED CABLES

Contains a tinned copper braid (25 mm² - L=500 mm), a tinned copper wire for cleating and water sealing mastic.

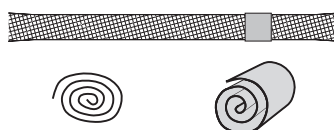

ORDERING INSTRUCTIONS

Order
Kit MT for 12 kV or 24 kV
applications.

APPLICATION

For use with connectors, receptacles and bushings with an interface A as described by CENELEC EN 50180 and 50181.

ORDERING INSTRUCTIONS

The type of bail restraint is defined by its intended use with different types of connector, receptacle and/or bushing.

To order the bail restraint, specify the type needed.

STANDARD BAIL FOR 200LR BA 200LR

For use with:

1. 200LR elbow connector
2. an interface A equipment bushing

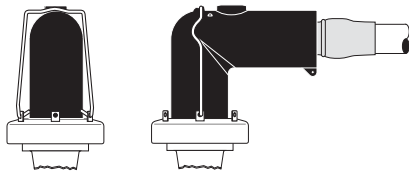

The complete K200LR elbow connector kit comprises 3 pieces of the standard bail BA 200LR.

STANDARD BAIL FOR 200SR BA 200SR

For use with:

1. 200SR straight connector
2. an interface A equipment bushing

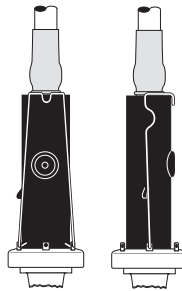

The complete K200SR elbow connector kit comprises 3 pieces of the standard bail BA 200SR.

UNI-BAIL FOR 200LR

This universal bail offers a solution for bushings that are not compliant (cfr. deviating height of the "bushing tabs") with the bushing standard EN 50180. The height of the bail can be adjusted using the two wing-nuts.

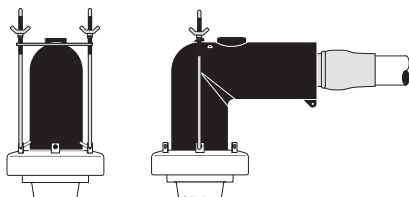

To order the 200LR uni-bail, simply specify:
3x(BA 200LR-UNI)

UNI-BAIL FOR 200SR

This universal bail offers a solution for bushings that are not compliant (cfr. deviating height of the "bushing tabs") with the bushing standard EN 50180. The height of the bail can be adjusted using the two wing-nuts.

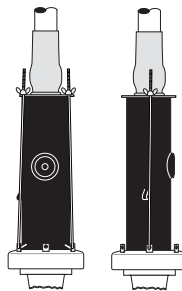

To order the 200SR uni-bail, simply specify:
3x(BA 200SR-UNI)

POSSIBLE ARRANGEMENTS

BAIL SADDLE

Different cable arrangements are possible by using the BAIL SADDLE 200X/T.

The standard bails that are delivered in the kit with the 200LR elbow connectors, 200SR straight connector, 156SA surge arrester... are fitting in the tabs of the bail saddle. No extra or special bails are required.

APPLICATION

For use with 150S in-line junction, 200T separable tee connector and 200X separable cross connector.

ORDERING INSTRUCTIONS

Bail saddle 200X/T
Item nr 25690

200LR+150S+200LR

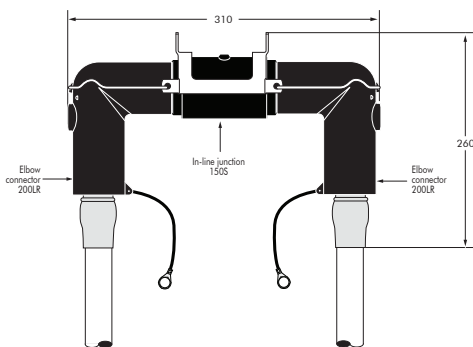

200SR+150S+200SR

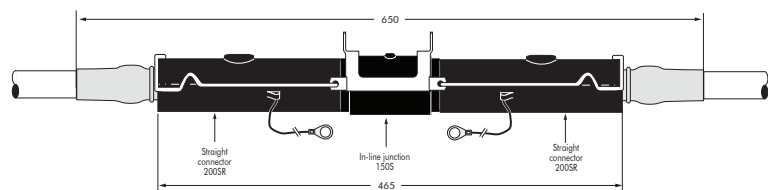

200LR+200T+156SA

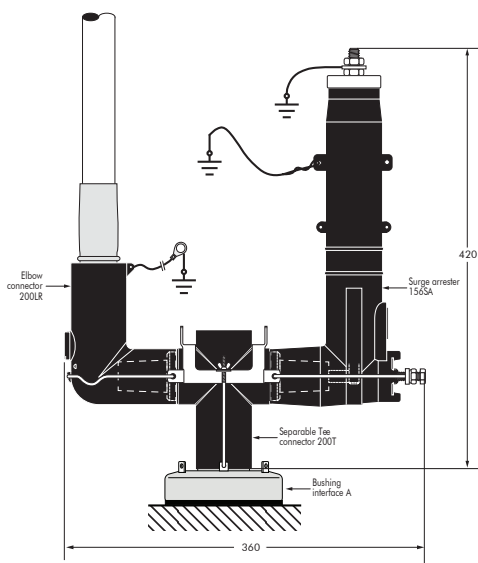

200SR+200T+200SR

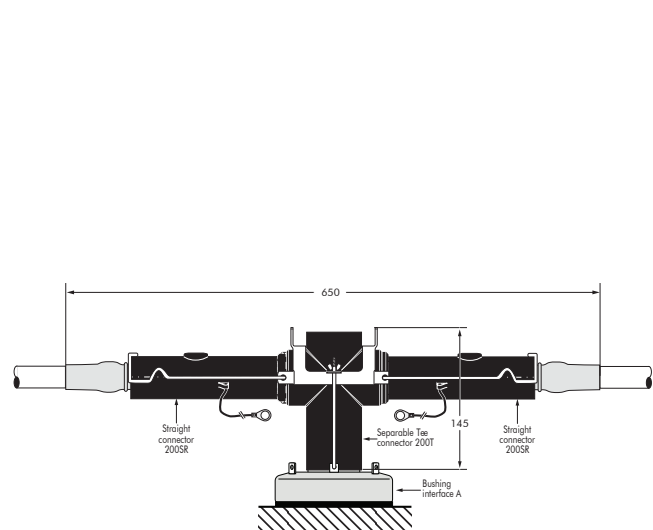

200LR+200SR+200X+200LR

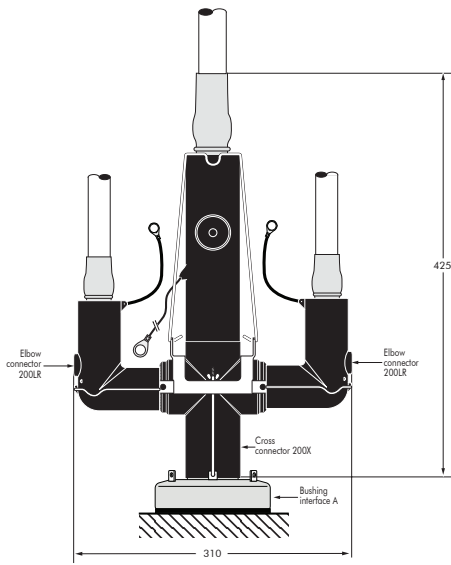

200SR+200LR+200X+200SR

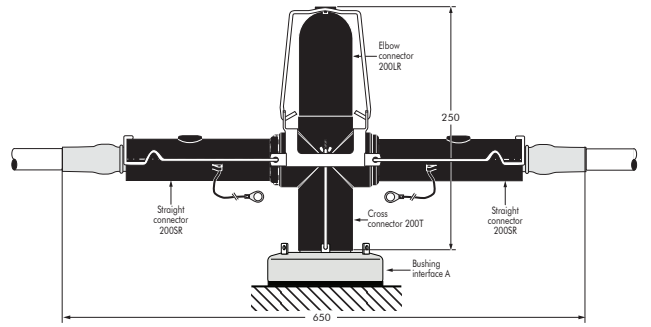

OTHER BAIL RESTRAINTS

ORDERING INSTRUCTIONS

The type of bail restraint is defined by its intended use with different types of connector, receptacle and/or bushing.

To order the bail restraint, specify the type needed.

BAIL BEAM 150DP

item nr 21733

For use with:

1. (K)150DP dead-end plug
2. (K)200LR elbow connector or (K)200SR straight connector (The standard bails in the connector kit are fitting the tabs of the bail beam)

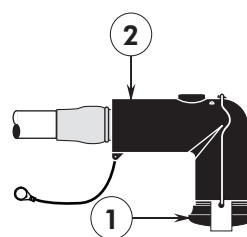
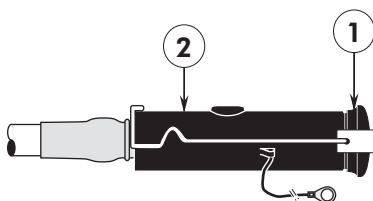

BAIL 150DR

item nr 20836

For use with:

1. (K)150DR dead-end receptacle
2. An Interface A equipment bushing or in combination with the bail saddle

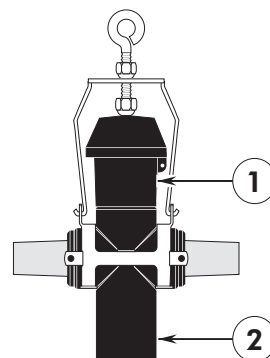
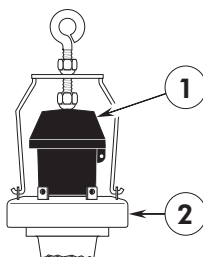

BAIL ASSY 151SP+150DR

item nr 20786

For use with:

1. (K)151SP straight plug
2. (K)150DR dead-end receptacle

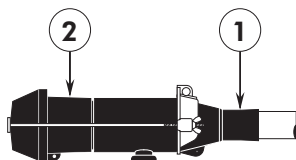

BAIL ASSY 151SP+200X/T

item nr 23093

For use with:

1. (K)151SP straight plug
2. (K)200T or (K)200X (shown)

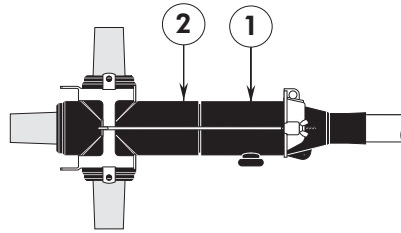

BAIL ASSY 151SP+200SR

item nr 28521

For use with:

1. (K)151SP straight plug
2. (K)200SR straight connector

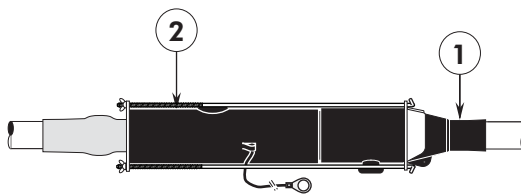

BAIL ASSY 151SP+200LR

item nr 28293

For use with:

1. (K)151SP straight plug
2. (K)200LR elbow connector

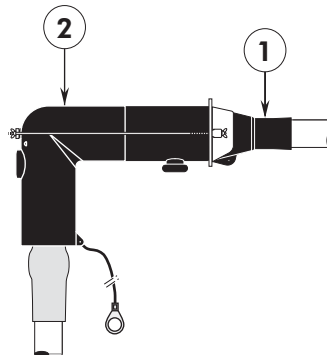



Nexans Network Solutions N.V. - Div. Euromold
Zuid III, Industrielaan 12, B-9320 Erembodegem
Tel.: +32(0)53 85 02 11 • power.accessories@nexans.com • www.nexans.com/power_accessories

Catalogue also available on Website and Mobile Apps



Find out more about Nexans Power Accessories.