

EUROMOLD®

INTERFACE D
MEDIUM VOLTAGE SEPARABLE
CONNECTORS AND BUSHINGS

CATALOGUE 2022

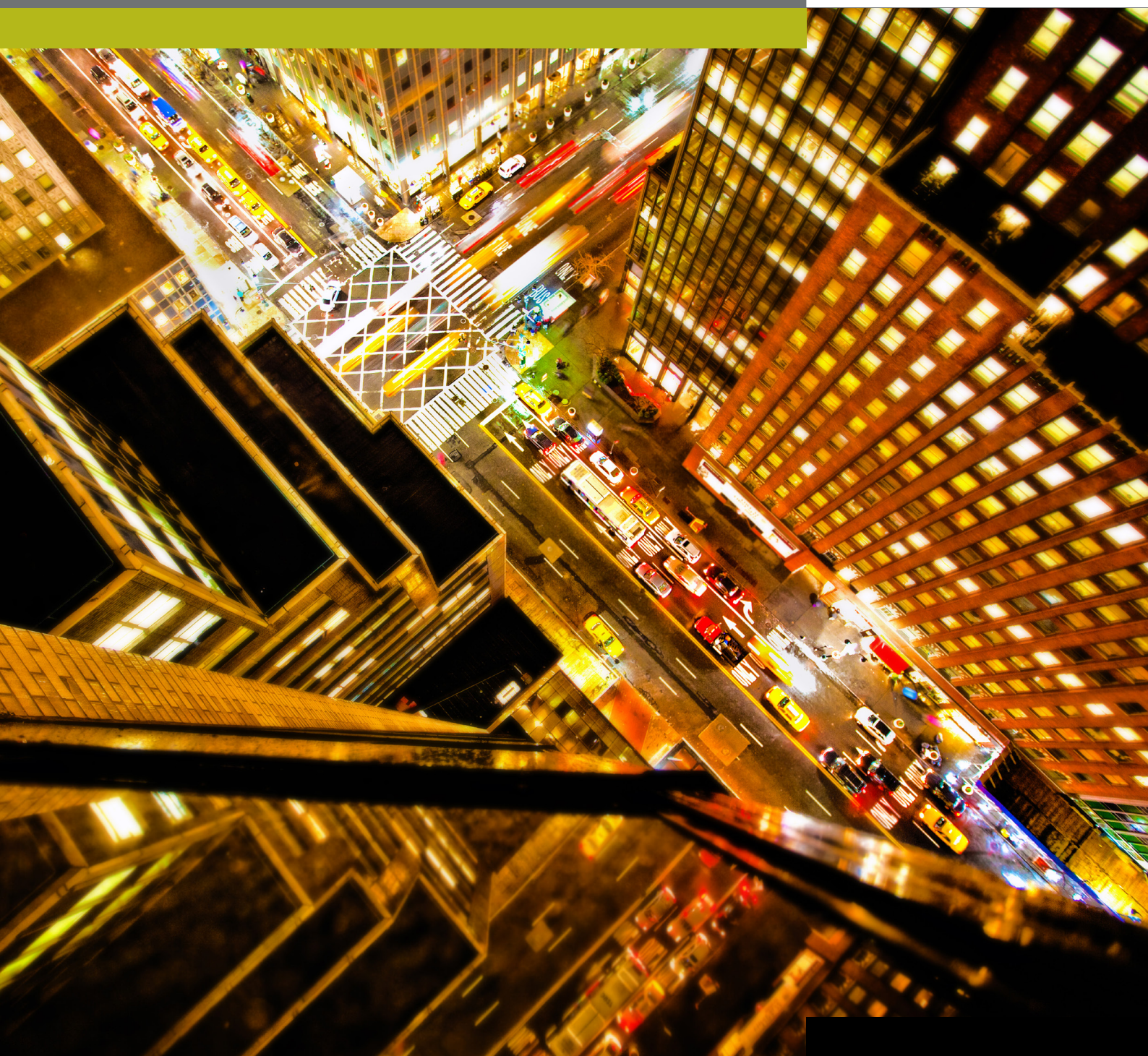

COMPANY PRESENTATION



EUROMOLD

Euromold is the leading European specialised designer, manufacturer and distributor of prefabricated cable accessories for medium voltage energy distribution. Euromold provides a complete range of accessories for underground cables: premoulded EPDM rubber connectors for cables and epoxy bushings for transformers and switchgear, as well as a large range of cold-shrinkable terminations and joints from 12 to 42 kV. Euromold is also the manufacturer of electrical components for the high voltage accessories of the Nexans group.

ISO 9001 Certificate

Since 1992, Euromold's commitment to quality is demonstrated by its ISO 9001 certification.

International standards

All our products meet the International standards like CENELEC HD 629.1, CENELEC EN 50180, IEC 60137, IEC 60502-4... or country specifications. Official certificates, CESI, KEMA, ATEX... prove the conformity of our products. Long duration tests of existing or new products are continuously performed in our test fields.

Laboratory accreditation

Since June 2000, Euromold's independent ELAB laboratory obtained the BELAC accreditation no.144-TEST conform with the European standards for laboratories ISO 17025 for electrical testing of low and medium voltage cable accessories according to the international standards EN 50393, IEC 60502-4, IEC 61442 and HD 629.



While every care is taken to ensure that the information contained in this publication is correct, no legal responsibility can be accepted for any inaccuracy. Nexans Network Solutions N.V. - Div. Euromold reserves the right to alter or modify the characteristics of its products described in this catalogue as standards and technology evolve.

SEPARABLE CONNECTORS AND BUSHINGS

INTERFACE D

TABLE OF CONTENTS

- 676LRA - tee connector
- 670AR-2 - equipment bushing
- Accessories
- Possible arrangements

INTERFACE D1 & D2

Dimensions according to European CENELEC EN 50180 and 50181 (in mm).

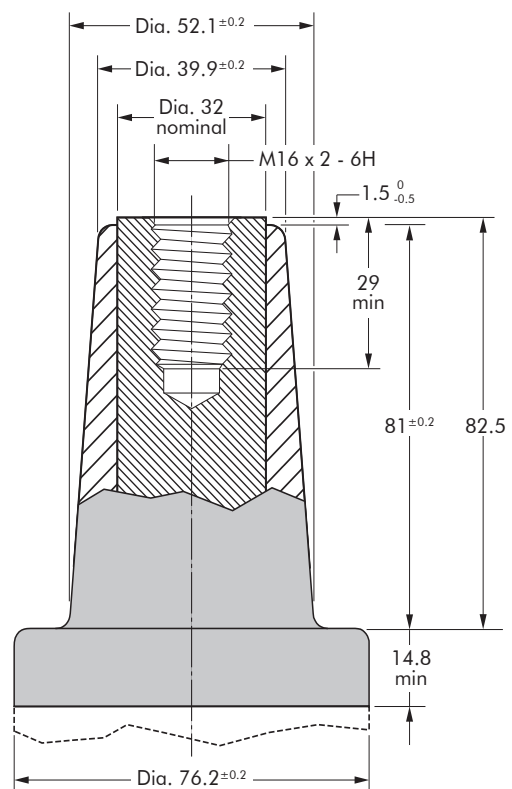

In mm.

CONNECTING POSSIBILITIES

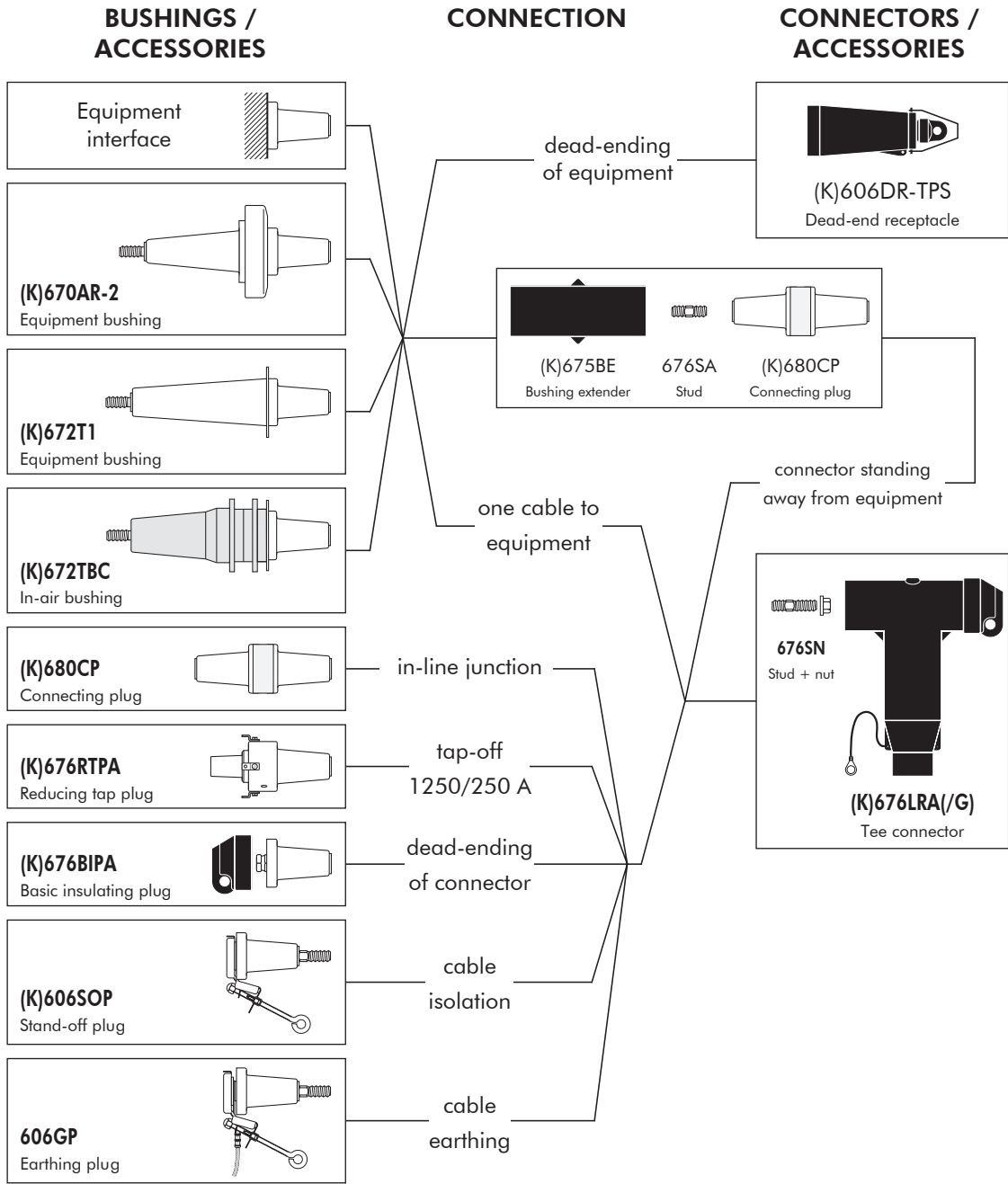

APPLICATION

Separable tee connector designed to connect polymeric insulated cable to equipment (transformers, switchgear, motors...).

Also connects cable to cable, using the appropriate mating part.

TECHNICAL CHARACTERISTICS

- A thick conductive EPDM jacket provides a total safe to touch screen.
- Each separable connector is tested for AC withstand and partial discharge prior to leaving the factory.



DESIGN

Separable connector comprising:

1. Conductive EPDM insert.
2. Conductive EPDM jacket.
3. Insulating EPDM layer moulded between the insert and the jacket.
4. Type D - 1250 A interface as described by CENELEC EN 50180 and 50181.
5. Conductor contact.
6. Basic insulating plug (with VD point).
7. Cable reducer.
8. Conductive rubber cap.
9. Threaded stud.
10. Earthing lead.

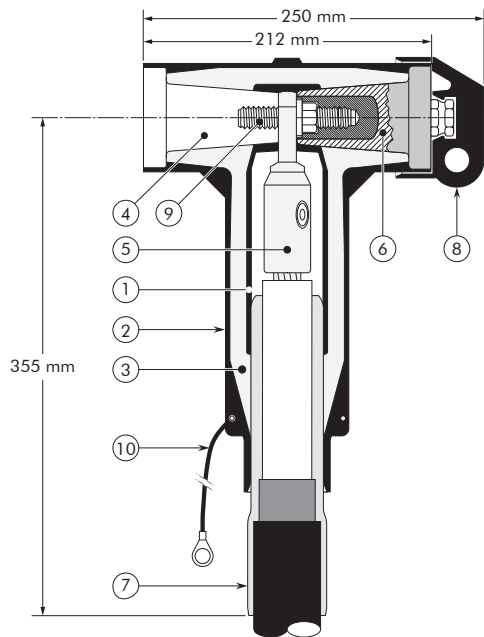

6/10 (12) kV
6.35/11 (12) kV
8.7/15 (17.5) kV
12/20 (24) kV
12.7/22 (24) kV

Up to 24 kV - 1250 A

EUROMOLD®

The screen break design enables cable outer sheath testing without removing or dismantling the connector.

SPECIFICATIONS AND STANDARDS

The 676LRA separable connector meets the requirements of CENELEC HD 629.1.

Separable connector type	Voltage U_m (kV)	Current I_r (A)	Conductor sizes (mm ²)	
			min.	max.
676LRA/G	12	1250	50	630
K676LRA/G	24	1250	35	630

06/2022

KIT CONTENTS

The complete (K)676LRA tee connector kit comprises the following components:

The kit also comprises silicone grease, wipers, field control mastic and installation instructions.

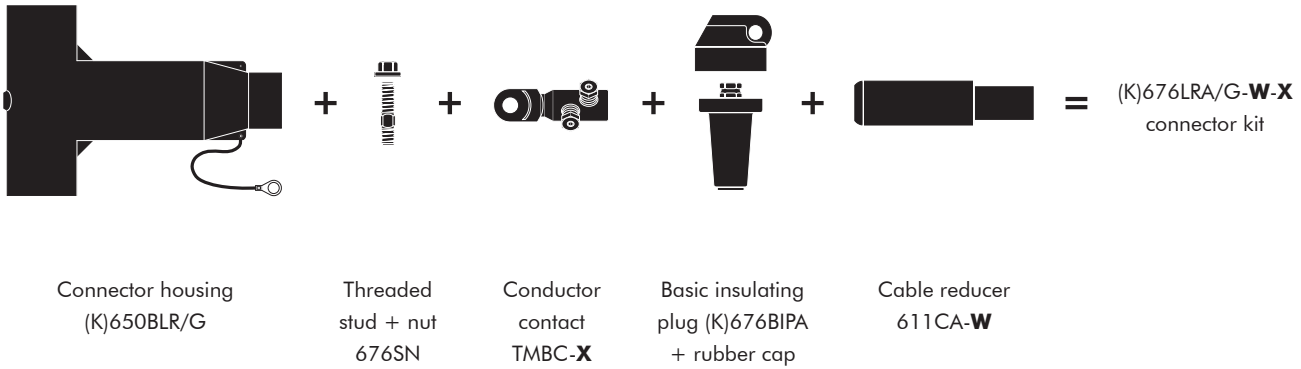

ORDERING INSTRUCTIONS

Select the part number which gives the best centring to the cable core insulation diameter and substitute **X** using table X, according to your conductor size and type.
Add a 'K' for use up to 24 kV.

TABLE W

Ordering part number	Dia. over core insulation (mm)	
	min.	max.
676LRA/G-15-X	16.0	22.0
676LRA/G-19-X	20.0	26.5
676LRA/G-22-X	23.5	31.0
676LRA/G-27-X	28.5	37.5
676LRA/G-32-X	34.0	42.5
676LRA/G-37-X	39.0	48.5
676LRA/G-43-X	45.5	56.0

EXAMPLE:

The copper wire screened cable is 24 kV, 630 mm² stranded aluminium with a diameter over core insulation of 44.0 mm.
Order a K676LRA/G-37-400.630UN5 tee connector kit.

TABLE X

Conductor sizes (mm ²)	Aluminium and copper conductor		
	Bolted		
35	16.95UN5		
50			
70			
95			
120		95.300UN5	
150			
185			
240			
300			
400			
500			
630			400.630UN5

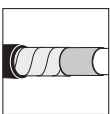

For use with copper tape screened cables.
Order: Kit MT.



For use with other cable types.
Please contact our representative.



For outdoor applications.
Order: +MWS.



For use in potentially explosive atmospheres (for 12 kV max.).
Order: -/ATEX.



Components can be ordered individually.

670AR-2

INTERFACE D EQUIPMENT BUSHING

APPLICATION

For use in equipment insulated with oil fluid, typically for transformers, switchgear, capacitors...

TECHNICAL CHARACTERISTICS

Each bushing is tested for AC withstand and partial discharge prior to leaving the factory.



SPECIFICATIONS AND STANDARDS

The bolted type equipment bushings 670AR-2 are moulded epoxy insulated parts and meet the requirements of CENELEC EN 50180 and IEC 60137.

ORDERING INSTRUCTIONS

To order the equipment bushing, specify the type. The bushings can be supplied with an earth jumper (/J) or an earth plate (/GS). This earth connection must be specified when ordering. E.g. K670AR-2/GS.

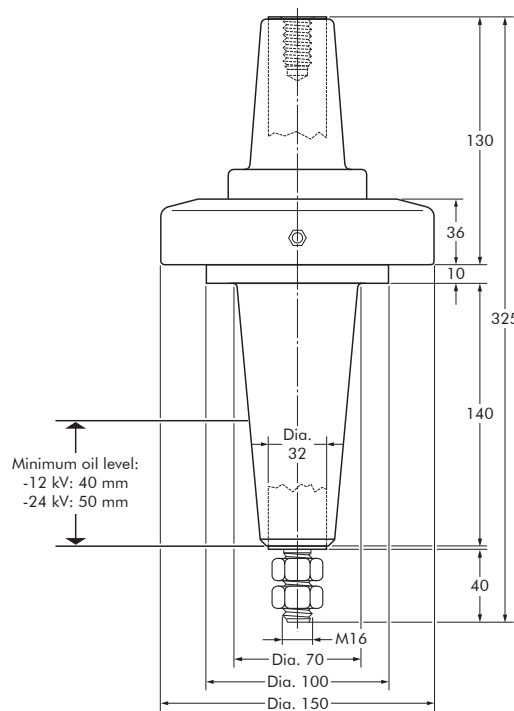

6/10 (12) kV
6,35/11 (12) kV
8,7/15 (17,5) kV
12/20 (24) kV
12,7/22 (24) kV

Up to 24 kV - 1250 A

EUROMOLD®

In mm.

Equipment bushing type	Voltage Um (kV)	Current Ir (A)
670AR-2	12	1250
K670AR-2	24	1250

06/2022

FIXINGS FOR EQUIPMENT BUSHINGS

670AR-2/GS BUSHING

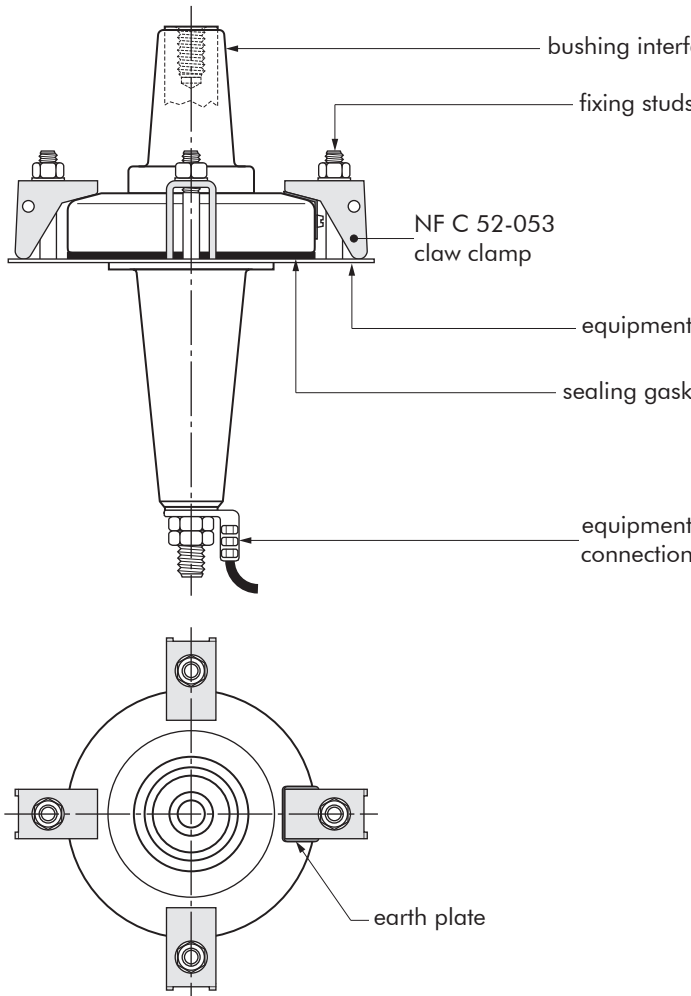

670AR-2/J BUSHING

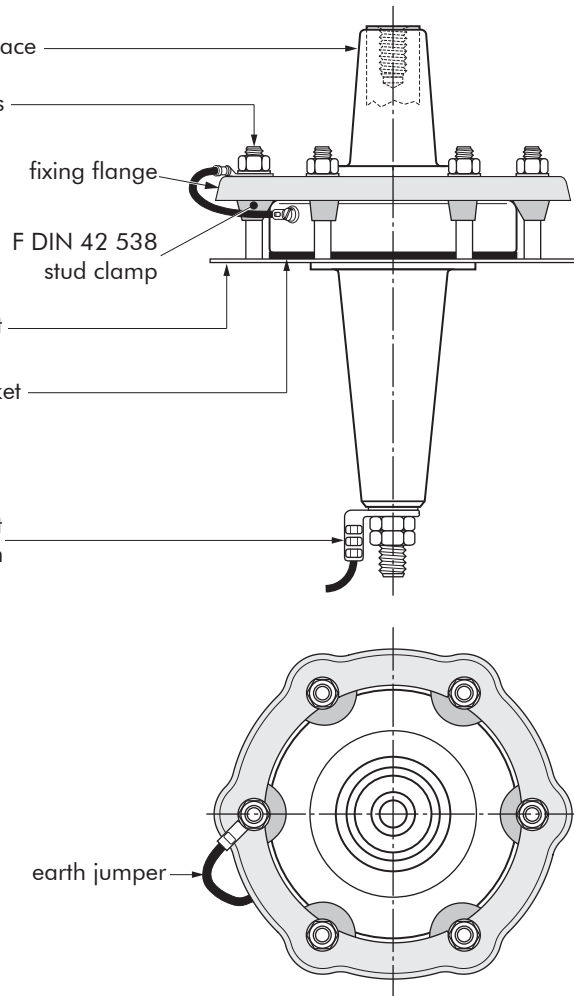

BUSHING CLAMPING KIT

To order the bushing clamping kit, according to NFC 52-053 standards, simply specify: KBC - NFC 52-053 /400 SERIES.

Contents: - 4 x claw clamp NF
- 1 x sealing gasket.

BUSHING CLAMPING KIT

To order the bushing clamping kit with DIN style fixing flange, simply specify: KBC - RING CLAMP 3.

Contents: - 1 x fixing flange
Ø150 mm
- 6 x stud clamp
F DIN 42 538
- 1 x sealing gasket.

FIXING DIMENSIONS STANDARDS NF C 52-053

French standards.

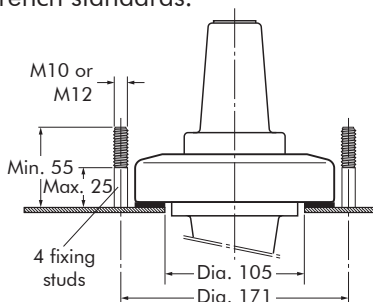

FIXING DIMENSIONS

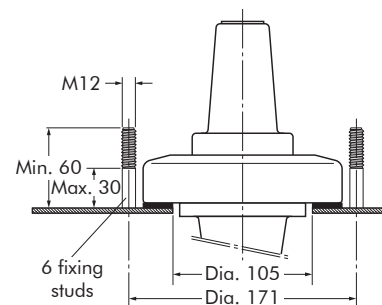

In mm.

ACCESSORIES

APPLICATION

For use with connectors and bushings with an interface D as described by CENELEC EN 50180 and 50181.

TECHNICAL CHARACTERISTICS

All these products, except the earthing plug, are tested for AC withstand and partial discharge prior to leaving the factory.

6/10 (12) kV
6.35/11 (12) kV
8.7/15 (17.5) kV
12/20 (24) kV
12.7/22 (24) kV

Up to 24 kV

606DR-TPS DEAD-END RECEPTACLE

Fits over a bushing with a type D interface to provide 'dead-end' facility.

Contains a capacitive test point for checking circuit conditions.

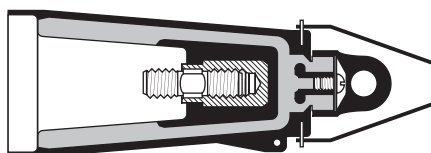

ORDERING INSTRUCTIONS

Order 606DR-TPS for 12 kV or K606DR-TPS for 24 kV applications. The dead-end receptacle can be supplied with an earth lead. Order: -/G. E.g. 606DR-TPS/G.

606SOP STAND-OFF PLUG

Is designed to support and 'dead-end' connectors with a type D interface when removed from equipment.

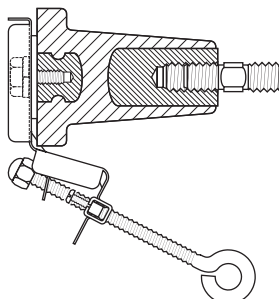

ORDERING INSTRUCTIONS

Order 606SOP for 12 kV or K606SOP for 24 kV applications.

606GP EARTHING PLUG

Is designed to support and earth connectors with a type D interface when removed from equipment.

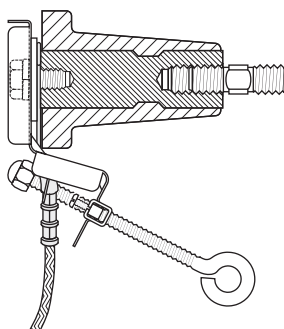

ORDERING INSTRUCTIONS

Order 606GP for 12 or 24 kV applications.

06/2022

675BE BUSHING EXTENDER

Provides an extension piece to allow cables to stand away from equipment.
Is used in conjunction with the 680CP connecting plug.

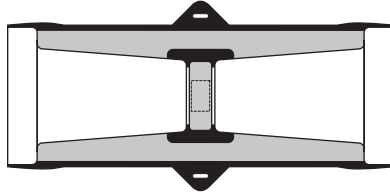

ORDERING INSTRUCTIONS

Order
675BE for 12 kV or
K675BE for 24 kV
applications.

676BIPA BASIC INSULATING PLUG

Acts as a tightening nut for the 676LRA/G tee connector kits.
The plug contains a voltage detection point.
The conductive rubber protection cap is included.

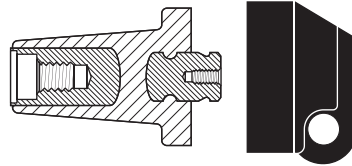

ORDERING INSTRUCTIONS

Order
676BIPA for 12 kV or
K676BIPA for 24 kV
applications.

680CP CONNECTING PLUG

For connecting two or more connectors with a type D interface together, thus creating a separable cable joint or a multiple cable connection to equipment.

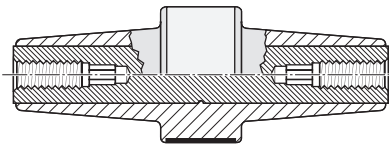

ORDERING INSTRUCTIONS

Order
680CP for 12 kV or
K680CP for 24 kV
applications.
Order: -/ATEX for use in
potentially explosive atmospheres
(for 12 kV max.).

676RTPA REDUCING TAP PLUG

Provides a type A interface to connectors with a type D interface.
A 'C' spanner, 600SW, is used to tighten the reducing tap plug onto its mating part.

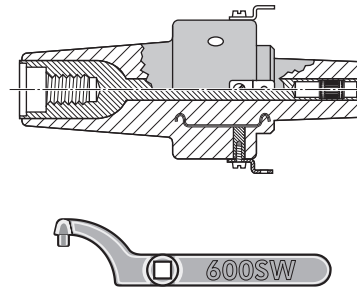

ORDERING INSTRUCTIONS

Order
676RTPA for 12 kV or
K676RTPA for 24 kV
applications.
Order 600SW for the 'C'
spanner.

KIT MT EARTHING KIT FOR COPPER TAPE SCREENED CABLES

Contains a tinned copper braid (25 mm² - L = 500 mm), a tinned copper wire for cleating and water sealing mastic.

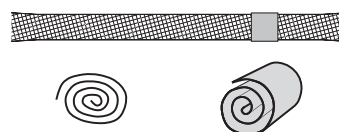

ORDERING INSTRUCTIONS

Order
Kit MT for 12 kV or 24 kV
applications.

POSSIBLE ARRANGEMENTS

676LRA/G

Single cable arrangement.
Order 676LRA/G for 12 kV or
K676LRA/G for 24 kV
applications.

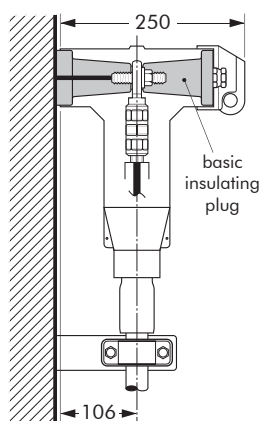

676LRA/G-P2

Dual cable arrangement.
Order 676LRA/G-P2 for 12 kV
or K676LRA/G-P2 for 24 kV
applications.

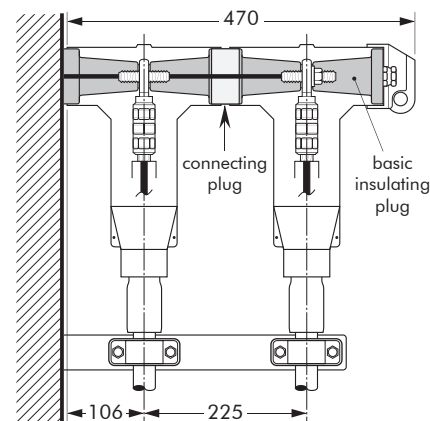

676LRA/G-P3

Triple cable arrangement.
Order 676LRA/G-P3 for 12 kV
or K676LRA/G-P3 for 24 kV
applications.

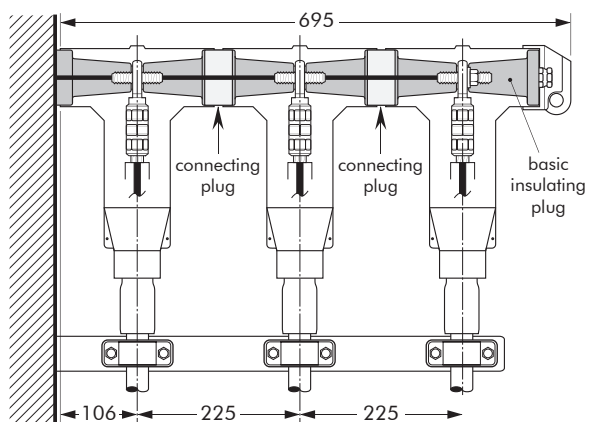

676LRA/G-P4

Single cable arrangement with
tap-off.
Order 676LRA/G-P4 for 12 kV
or K676LRA/G-P4 for 24 kV
applications.

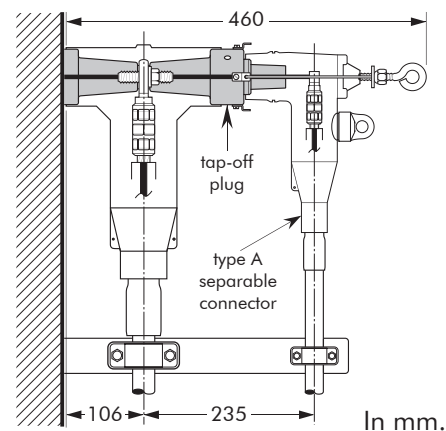

In mm.

06/2022

676LRA/G-P5

Dual cable arrangement with tap-off.
Order 676LRA/G-P5 for 12 kV
or K676LRA/G-P5 for 24 kV
applications.

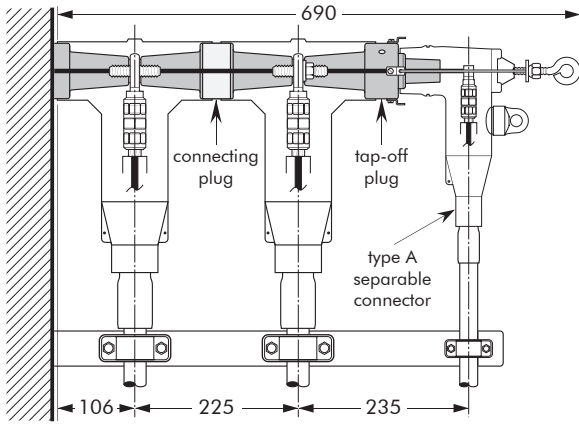

676LRA/G-P6

Connector standing away from equipment.
Order 676LRA/G-P6 for 12 kV
or K676LRA/G-P6 for 24 kV
applications.

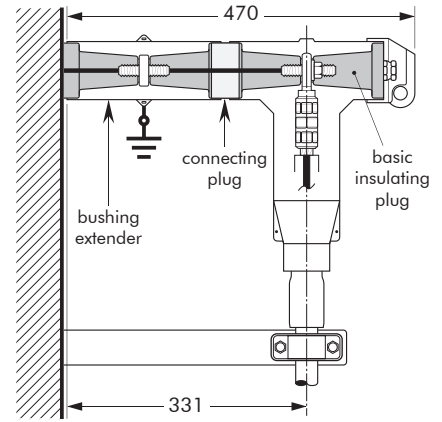

676LRA/G-L1

Dead-ending.
Order 676LRA/G-L1 for 12 kV
or K676LRA/G-L1 for 24 kV
applications.

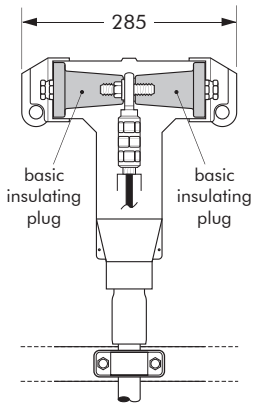

676LRA/G-L3

3-way connection.
Order 676LRA/G-L3 for 12 kV
or K676LRA/G-L3 for 24 kV
applications.

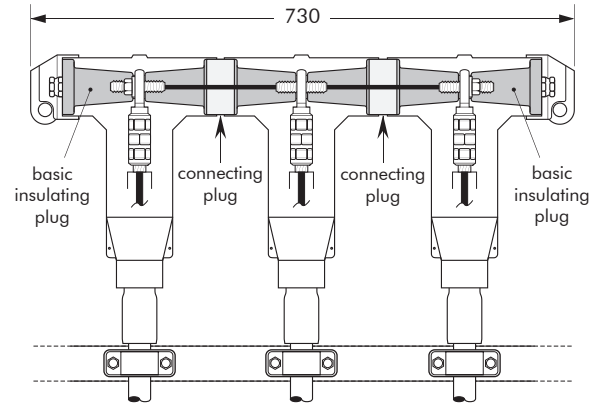

676LRA/G-L2

2-way connection.
Order 676LRA/G-L2 for 12 kV
or K676LRA/G-L2 for 24 kV
applications.

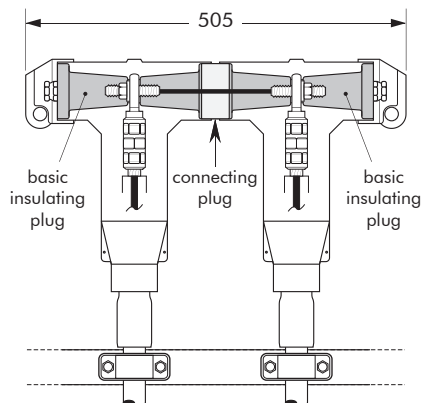

676LRA/G-L4

4-way connection.
Order 676LRA/G-L4 for 12 kV
or K676LRA/G-L4 for 24 kV
applications.

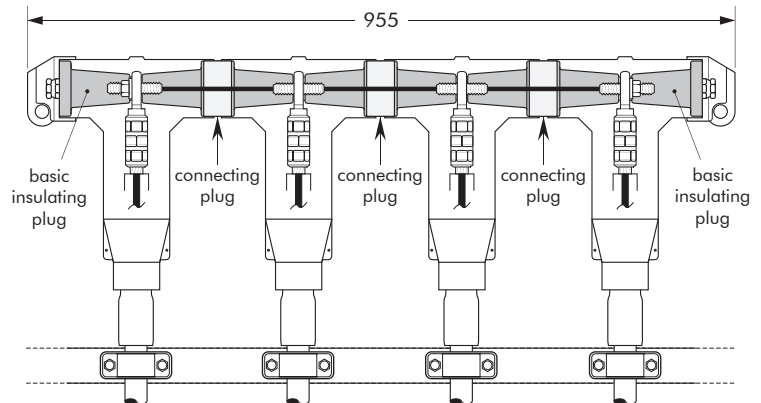

676LRA/G-L5

2-way connection with tap-off.
Order 676LRA/G-L5 for 12 kV
or K676LRA/G-L5 for 24 kV
applications.

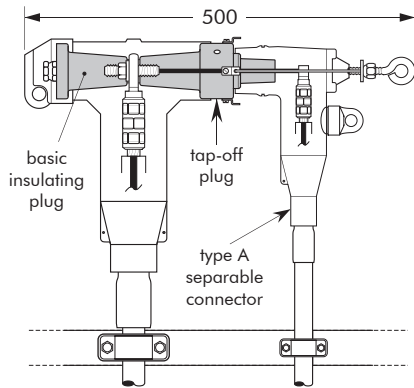

676LRA/G-L6

3-way connection with two
tap-offs.
Order 676LRA/G-L6 for 12 kV
or K676LRA/G-L6 for 24 kV
applications.

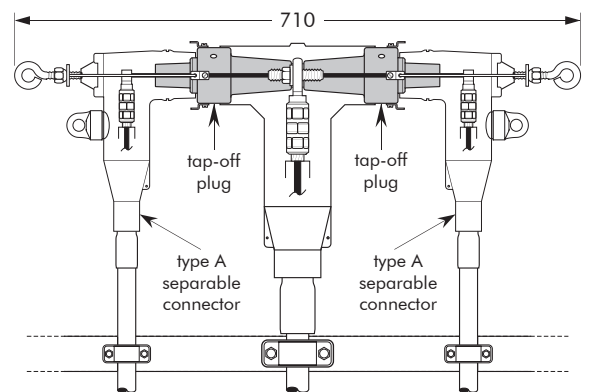

676LRA/G-L7

3-way connection with one tap-off.
Order 676LRA/G-L7 for 12 kV
or K676LRA/G-L7 for 24 kV
applications.

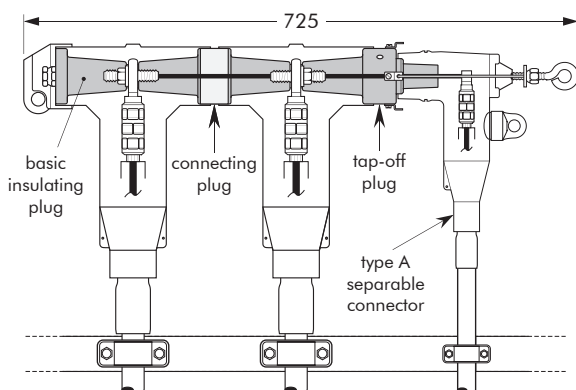

676LRA/G-L8

4-way connection with two
tap-offs.
Order 676LRA/G-L8 for 12 kV
or K676LRA/G-L8 for 24 kV
applications.

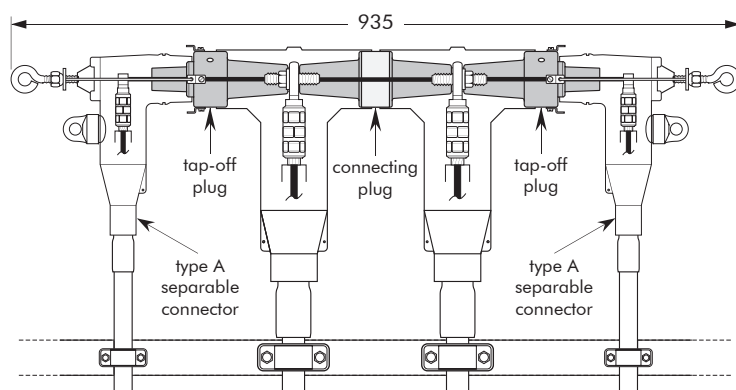

676LRA/G-L9

4-way connection with one tap-off.

Order 676LRA/G-L9 for 12 kV

or K676LRA/G-L9 for 24 kV

applications.

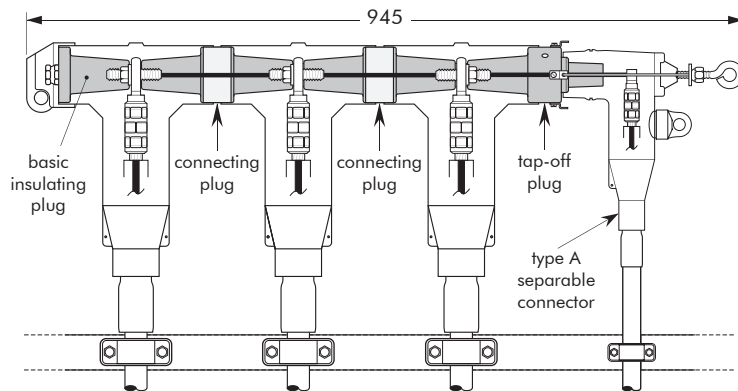

CONNECTOR ON STAND-OFF PLUG

Order 606SOP for 12 kV or

K606SOP for 24 kV applications.

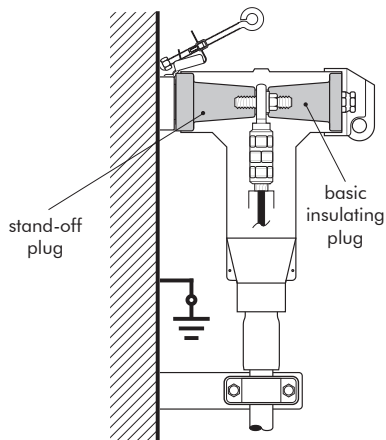

CONNECTOR ON EARTHING PLUG

Order 606GP for 12 kV and

24 kV applications.

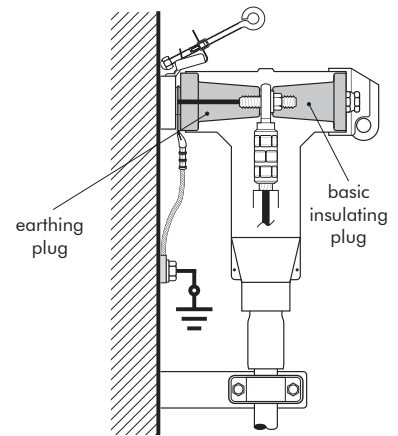

In mm.

NOTES



Nexans Network Solutions N.V. - Div. Euromold
Zuid III, Industrielaan 12, B-9320 Erembodegem
Tel.: +32(0)53 85 02 11 • sales.euromold@nexans.com • www.euromold.be

Catalogue also available on Website and Mobile Apps



Find out more about Nexans Power Accessories.