

**LSM****CABLE JOINT**

FOR (7)(5) 4-CORE CABLES TO 1 KV

**DESITEK**

## ASSEMBLY INSTRUCTIONS

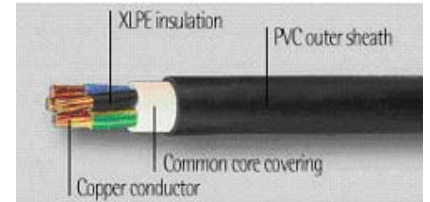
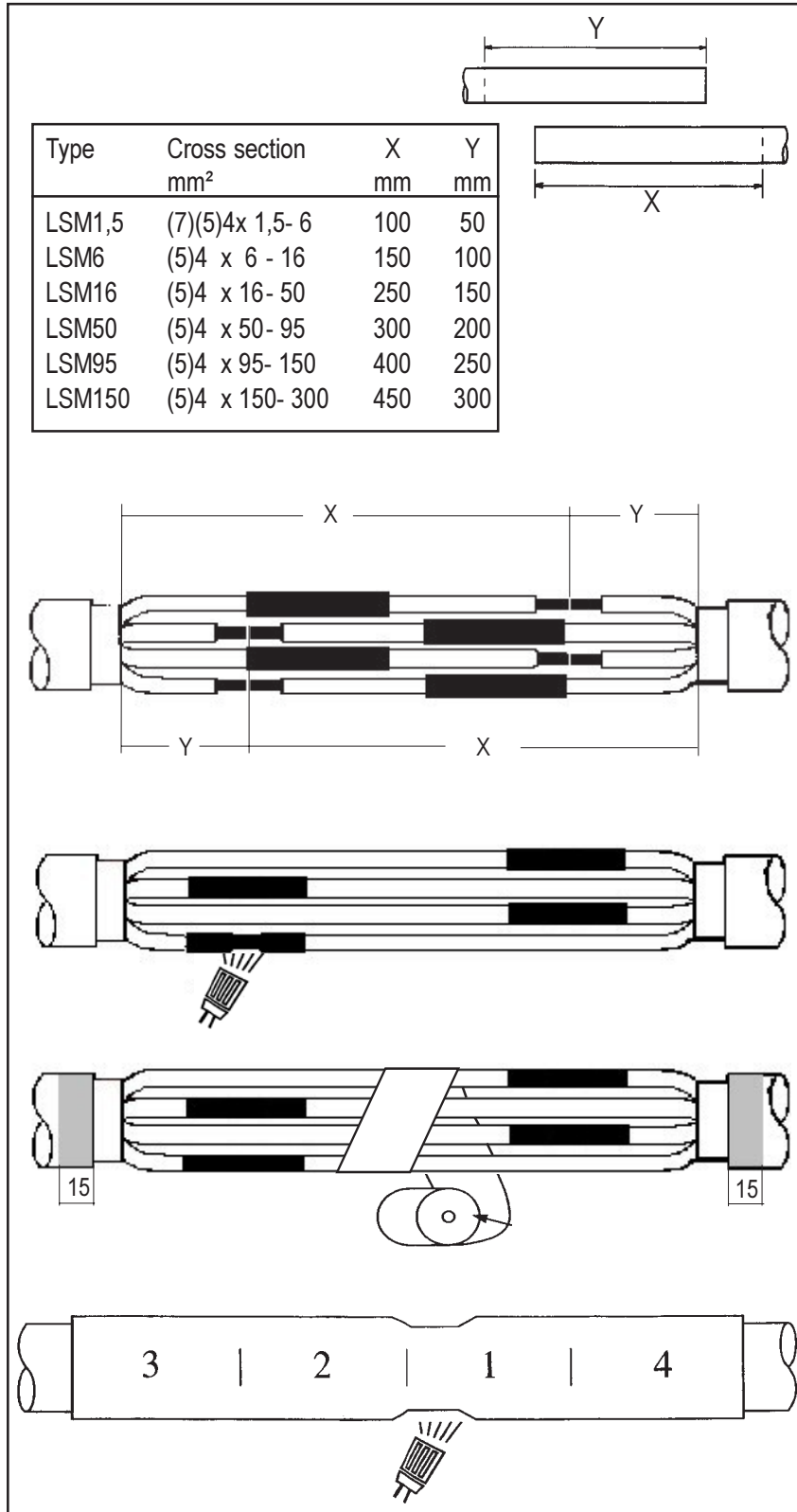

These assembly instructions are designed for this type of cable only. For other types of cable please contact us.

1. Arrange cables in parallel with the necessary overlap if you want to dislocate connection, and remove cable sheath to X and Y measurement respectively. If necessary apply a layer of tape by the edge of the cable sheath.
2. Place the outer shrinkable tube onto one of the cables.
3. Adjust and strip conductors after conductor connectors - dislocate connections for a slimmer joint.
4. Clean isolation and pull isolation tubes onto conductors.
5. Connect conductors using crimping sleeves and remove any burrs.
6. Place isolation tubes symmetrically on top of the crimping sleeve and shrink tubes from the middle and outwards.
7. If necessary hold conductors together with tape.
8. Clean and degrease the cable sheath in area shown to 15 cm from the edge of the cable sheath. Put outer shrinkable tube into place and shrink tube from the middle as shown.