



Power cables accessories
for use in potentially explosive atmospheres

Catalogue 2013



05/2013

EUROMOLD

Euromold is the leading European specialised designer, manufacturer and distributor of prefabricated cable accessories for medium voltage energy distribution. Euromold provides a complete range of accessories for underground cables: premoulded EPDM rubber connectors for cables and epoxy bushings for transformers and switchgear, as well as a large range of cold-shrinkable terminations and joints from 12 to 42 kV. Euromold is also the manufacturer of electrical components for the high voltage accessories of the Nexans group.

ISO 9001 Certificate

Since 1992, Euromold's commitment to quality is demonstrated by its ISO 9001 certification.

International standards

All our products meet the International standards like CENELEC HD 629.1, CENELEC EN 50180, IEC 60137, IEC 60502-4... or country specifications. Official certificates, CESI, KEMA, ATEX... prove the conformity of our products. Long duration tests of existing or new products are continuously performed in our test fields.

Laboratory accreditation

Since June 2000, Euromold's independent ELAB laboratory obtained the BELAC accreditation no.144-TEST conform with the European standards for laboratories ISO 17025 for electrical testing of low and medium voltage cable accessories according to the international standards EN 50393, IEC 60502-4, IEC 61442 and HD 629.

While every care is taken to ensure that the information contained in this publication is correct, no legal responsibility can be accepted for any inaccuracy. Nexans Network Solutions N.V. - Div. Euromold reserves the right to alter or modify the characteristics of its products described in this catalogue as standards and technology evolve.

Power accessories for use in potentially explosive atmospheres



I Table of contents

| | |
|---|----|
| K400TB/G-ATEX - interface C - tee connector | 12 |
| K430TB/G-ATEX - interface C - tee connector | 14 |
| K440TB/G-ATEX - interface C - tee connector | 16 |
| K484TB/G-ATEX - interface C - tee connector | 18 |
| K300PBM/G-ATEX - coupling connector for 430TB/G | 20 |
| K804PB/G-ATEX - coupling connector for 484TB/G | 22 |
| 400PB-XSA-ATEX - interface C - surge arrester | 24 |
| 300SA-ATEX - surge arrester for 430TB connector | 25 |
| 800SA-ATEX - surge arrester for 484TB connector | 26 |
| K400AR-3-ATEX - interface C1 - equipment bushing | 27 |
| K400AR-4-ATEX - interface C2 - equipment bushing | 28 |
| K400AR-6-ATEX - interface C1 - equipment bushing | 29 |
| 400A-24B-ATEX - interface C1 - in-air bushing | 30 |
| Accessories - interface C | 31 |
| K676LRA/G-ATEX - interface D - tee connector | 32 |
| K670AR-2-ATEX - interface D - equipment bushing | 34 |
| K672T1-ATEX - interface D - equipment bushing | 35 |
| K672TBC-ATEX - interface D - equipment bushing | 36 |
| Accessories - interface D | 37 |
| K944TB/G-ATEX - interface F - asymmetrical tee connector | 38 |
| K900AR-1/2/3/4-ATEX - interface F1, F2 & F3 - equipment bushing | 40 |

Technical information Nexans PABG

Introduction

We received a ATEX certification for some of our products.

These pages aim at providing information on ATEX and on the Nexans-Euromold products qualified according to this directive.

Equipment intended for use in potentially explosive atmospheres must conform to the "ATEX" Directive 94/9/EC. It is a harmonised standard which provides the technical requirements to be applied to equipment intended for use in potentially explosive atmospheres.

It is named after the French "ATmosphère EXplosible".

Manufacturers who apply these provisions are able to sell their equipment anywhere in Europe without any further requirements with respect to the risks covered.

The directive covers a large range of equipment, including those used on fixed offshore platforms, in petrochemical

plants, mines, flour mills and other areas where a potentially explosive atmosphere may be present.

In very broad terms, there are three pre-conditions for the directive to apply:

1. The equipment must have its own source of ignition;
2. Be intended for use in a potentially explosive atmosphere (air mixtures);
3. Under normal atmospheric conditions.

The Directive has been mandatory from 1st July 2003.

Products

The products covered by this certification are:

- K400TB(/G)
- K430TB
- K440TB(/G)
- K484TB(/G)
- K300PBM
- KK804PB
- 400PB-XSA
- 300SA
- 800SA
- K676LRA(/G)
- K675BE
- 944TB
- K400AR-3



- K400AR-4
- K400AR-6
- 400A-24B
- K400CP-SC
- K440CP
- K670AR-2
- K672T1
- K672TBC
- K680CP
- K900AR-1, -2, -3, -4

These products cover a whole range of applications. If you have requests for other products, please assure yourself the request cannot be covered with these products as the certification of a new product is a long process.

All kitting of these products must be done in Erembodegem. ATEX products can never be sold in bulk.

Cables

The application of these products covers the whole range of sections as described in the Nexans-Euromold catalogue. It qualifies both the /G screen break version with 411/611CA and the older 400/655CA version. It covers

EUROMOLD
Erembodegem (BE)
ISSeP09ATEX023U
 II 2 G - Ex e IIC Gb
 II 2 D - Ex tb IIIC Db IP6X

the use with cables with aluminium and copper conductors. It allows the use of all bolted and crimped contacts (hexagonal and deep indent).



The original dossier refers to single core XLPE insulated cables with a copper wire screen. For other cable types, please contact us first.

The maximum rated voltage for these products is 11 kV (6/10 [12] kV – 75 kV BIL and 6.35/11 [12] kV – 95 kV BIL). This is due to the restriction written in an additional standard. For protection of electrical equipment used in potentially explosive gas atmospheres, standard IEC 60079-0:2007 gives the general requirements. The standard for each different type of protection is represented by a symbol; in our case: «e» for increased safety according IEC 60079-7:2006.

Marking and application

All ATEX certified products are specially marked. This marking reflects the scope of the certification.

Example:

1. K400TB – 11 kV – 630 A
2. ISSeP09ATEX023U
3. EUROMOLD
4. Erembodegem (BE)
5.  II 2 G - Ex e IIC Gb
 II 2 D - Ex tb IIIC Db IP6X
6. Serial number (including year of manufacturing).

The first (1) line gives the designation of series or type, the rated voltage and rated current.

The second (2) line refers to the certification dossier:

- ISSeP: the certification body (with no. 492 in Mons – Belgium)
- 09: year 2009
- ATEX

- 023: certification number
- U: this symbol placed after the certification number indicates that this certificate must not be mistaken for a certificate intended for an equipment. This partial certification may be used as a basis for certification of an equipment.

The third (3) and fourth (4) line are the name and address of the manufacturer.

The fifth (5) line describes where the product can be used:

- : the specific marking of explosion protection.
- II 2: equipment Group II: II is for use in all Ex-atmospheres, except mining (where the only flammable gas is methane). Category 2: For use in Zone 1 (Gases) and Zone 21 (Dusts) situations and designed to ensure a high level of safety, Its explosion protection system must ensure that the required level of safety is maintained even in the event of frequently occurring incidents or equipment malfunctions. Zone 1 and Zone 21 are areas in which an explosive atmosphere occurs occasionally in normal operations.
- G: gasses. The certificate is for use in areas in which explosive atmospheres are caused by mixtures of air and gasses, vapours and mists.
- D: dust. The certificate is also for use in areas in which explosive atmospheres are caused by air/dust mixtures.
- Ex: equipment is explosion protected.
- e: increased safety. This shows the product is conform to the additional standards
IEC 60079-0:2007,
IEC 60079-7:2006 and
IEC 60079-31:2008.
- tb: equipment with dust ignition protection by enclosure 't' with equipment protection level (EPL) 'Db'.

- II: explosion group - Gas group II: above ground industries. C: most easily ignited gases, e.g. hydrogen or acetylene.
- IP6X: Ingress Protection for electrical equipment (6: the device is totally protected against dust).

Certification and notification

- EC type examination certificate: a specimen has been evaluated by a notified body to meet the requirements of directive 94/9/EC.
- Production quality assurance notification following EN 13980: the producer operates a quality system for production, final equipment inspection and testing.

Limitations

Due to an additional qualification the limitation of "the connectors must be protected by an EEx agreed enclosure and providing a degree of protection of at least IP54", has become obsolete.

Info

For more information, please check out the EC web page : <http://europa.eu.int/comm/enterprise/atex/index.htm>



(1) **EC TYPE EXAMINATION CERTIFICATE**

(2) **Component intended for use on/in equipment or protective system
intended for use in potentially explosive atmospheres
Directive 94/9/EC**

(3) EC type examination certificate number: **ISSEP09ATEX023U**

(4) Component: Prefabricated cable accessories for medium and high voltage networks.

(5) Applicant – Manufacturer – ~~Authorized representative in the Community:~~
Nexans Network Solutions N.V. – Div. EUROMOLD

(6) Address: Zuid III – Industrielaan 12
9320 Erembodegem
Belgique



(7) This component and any acceptable variation thereto is specified in the schedule to this certificate and the documents therein referred to.

(8) ISSEP, notified body n° 0492 in accordance with article 9 of the Council Directive 94/9/EC of 23 March 1994, certifies that this component has been found to comply with the Essential Health and Safety Requirements relating to the design and construction of components intended for use in potentially explosive atmospheres given in annex II to the Directive.
The examination and test results are recorded in confidential report n° 08139.

(9) Compliance with the Essential Health and Safety Requirements has been assured by compliance with :
IEC 60079-0: 2007 IEC 60079-7: 2006
IEC 60079-31: 2008

(10) The symbol "U" placed after the certificate number indicates that this certificate must not be mistaken for a certificate intended for an equipment or protective system. This partial certification may be used as a basis for certification of an equipment or protective system.

(11) This EC TYPE EXAMINATION CERTIFICATE relates only to the design and construction of the specified component. If necessary, other requirements of this directive may apply to the manufacture and supply of this component.

(12) The marking of the component shall include the following indications:
 II 2 G - Ex e IIC Gb
 II 2 D - Ex tb IIIC Db IP6X

Colfontaine, le 26.05.2009.

Lambert Marcel,
Directeur.

INSTITUT SCIENTIFIQUE DE SERVICE PUBLIC
 Zoning A. Schweitzer, rue de la Platinerie
 B-7340 COLFONTAINE (Wasmès)
 Tél: ++ 32 65 610811 – Fax: ++ 32 65 610808

This certificate may only be reproduced in its entirety and without any change, schedule included



(13)

SCHEDULE

(14)

EC TYPE EXAMINATION CERTIFICATE N° ISSeP09ATEX023U

(15) Description of the component

- Prefabricated cable accessories for medium and high voltage networks.
- Accessories are of type:

| | | | |
|------------|-------------|-------------|--------------|
| K400TB(/G) | K430TB-630A | K440TB(/G) | K300PBM-630A |
| 400PB-XSA | 300SA | K676LRA(/G) | K675BE |
| K400AR-3 | K400AR-4 | 400A-24B | K400CP-SC |
| K440CP | K670AR-2 | K672T1 | K672TBC |
| K680CP | | | |

Technical descriptive documentation

- Notice "Manufacturing and product description of EPDM products" of 06.2008 (8 pages).
- Notice "Manufacturing and product description of epoxy products" of 06.2008 (3 pages).
- Drawing CA0894 rev. B of 22.04.2008 related to the connector 400TB and 400AR-3.
- Notice "Connecting possibilities" (2 pages).
- Notice "Material specifications" (3 pages).
- Drawing M2767 of 07.2004 related to the marking.
- Notices:

| <u>Material</u> | <u>Date</u> | <u>Pages</u> |
|-----------------|-------------|--------------|
| K400TB(/G) | 06.2008 | 49 |
| K430TB-630A | " | 33 |
| K440TB(/G) | " | 36 |
| K300PBM-630A | " | 24 |
| 400PB-XSA | " | 19 |
| 300SA | " | 12 |
| K676LRA(/G) | " | 44 |
| K675BE | " | 7 |
| K400AR-3 | " | 5 |
| K400AR-4 | " | 5 |
| 400A-24B | " | 6 |
| K400CP-SC | " | 12 |
| K440CP | " | 11 |
| K670AR-2 | " | 5 |
| K672T1 | " | 4 |
| K672TBC | " | 10 |
| K680CP | " | 12 |

This certificate may only be reproduced in its entirety and without any change, schedule included

SCHEDULE

EC TYPE EXAMINATION CERTIFICATE N° ISSeP09ATEX023U

Marking

- Name and address of the manufacturer (or registered trade mark).
- Manufacturer's type identification.
- Indication of the testing station followed by the certificate reference and by the symbol "U".
- ATEX specific marking / code : Ex II 2 G - Ex e IIC Gb
 Ex II 2 D - Ex tb IIIC Db IP6X
- Rated voltage and current.
- Marking normally required by the standards for construction of the component.

Routine verifications and tests: (Clause 27 of IEC 60079-0)

- The manufacturer shall make the routine verifications and tests necessary to ensure that the electrical apparatus produced complies with the specification submitted to the testing station together with the prototype or sample.
- He shall also perform the routine test 7.1 of IEC 60079-7 (electric strength test at $(2 U_n + 1000)$ Volt during at least 1 minute).

(16) Report n° 08139 completed by 23 documents.

(17) Special conditions for safe use

- Maximum temperature of the accessories in normal operation is 95 °C.

(18) Essential Health and Safety Requirements

The Essential Health and Safety Requirements are covered by:

- The conformity to the Standards at (9).
- All safety measures taken by the manufacturer and described in the descriptive documentation listed at (15).

This certificate may only be reproduced in its entirety and without any change, schedule included

VARIATION

EC TYPE EXAMINATION CERTIFICATE N° ISSeP09ATEX023U/2

(15) Equipment

- Prefabricated cable accessories for medium and high voltage networks.

Subject of the variation

- To permit the addition of new accessories to the existing range.
 - To permit the upgrade of the standards, standard IEC 60079-0: 2007 being superseded by standard EN 60079-0: 2012.

- New range of accessories

| | | | | |
|------------|-----------|------------|----------|-------------|
| K400TB(/G) | K430TB/G | K440TB(/G) | K484TB/G | K300PBM/G |
| K804PB/G | 400PB-XSA | 300SA | 800SA | K676LRA(/G) |
| K675BE | K944TB/G | K400AR-3 | K400AR-4 | K400AR-6 |
| 400A-24B | K440CP-SC | K440CP | K670AR-2 | K672T1 |
| K672TBC | K680CP | K900AR-1 | K900AR-2 | K900AR-3 |
| K900AR-4 | | | | |

Marking: Unchanged.

(16) Report N° 12096 completed by 33 documents.

(17) Special conditions for safe use: Unchanged.

(18) Essential Health and Safety Requirements: Unchanged.

Colfontaine, 30.01.2013.

INSTITUT SCIENTIFIQUE DE SERVICE PUBLIC
 Zoning A. Schweitzer, rue de la Platinerie
 B-7340 COLFONTAINE (Wasmes)
 Tél: ++ 32 65 610811 – Fax: ++ 32 65 610808
 colfontaine@issep.be

 Marcel LAMBERT,
 Director.

This document may not be used without the original certificate



ISSEP
Institut scientifique
de service public

Métrologie environnementale
Recherche - Analyses
Essais - Expertises

**Siège social
et site de Liège :**
Rue du Chéra, 200
B-4000 Liège
Tél : +32(0)4.229.83.11
Fax : +32(0)4.252.46.65

Site de Colfontaine :
Zoning A. Schweitzer,
rue de la Platinerie
B-7340 Colfontaine
Tél : +32(0)65.61.08.11
Fax : +32(0)65.61.08.08

e-mail :
direction@issep.be
site web :
http://www.issep.be



PRODUCTION QUALITY ASSURANCE NOTIFICATION

**Equipment or protective systems or components intended for use
in potentially explosive atmospheres
Directive 94/9/EC**

- (1)
- (2)
- (3) Notification number: **ISSEP09ATEX017/1**
- (4) Equipment or protective systems or components as listed:
- Development, design, manufacturing and sales of prefabricated cable accessories for medium and high voltage networks.
- (5) Applicant (Manufacturer or Authorized representative in the Community)
Name: Nexans Network Solutions
Div. Euromold
Address: ZUID III – Industrielaan 12
9320 Erembodegem
Belgium
- (6) Manufacturer
Name: Nexans Network Solutions
Div. Euromold
Address: ZUID III – Industrielaan 12
9320 Erembodegem
Belgium
- (7) ISSEP, notified body n° 0492 for annex IV in accordance with article 9 of the Council Directive 94/9/EC of 23 March 1994 notifies to the applicant that the actual manufacturer has a production quality system which complies to annex IV of the Directive
- (8) This notification is based on audit report n° 12095 issued the 20.12.2012.

This notification can be withdrawn if the manufacturer no longer satisfies the requirements of annexes IV and VII.

Results of periodical reassessment of the quality system are a part of this notification.
- (9) This notification is valid until 30.01.2016 and can be withdrawn if the manufacturer does not satisfy the production quality assurance reassessment.
- (10) According to article 10.1 of the Directive 94/9/EC, the "CE" marking shall be followed by the identification n° 0492 identifying the notified body involved in the production control stage.

Colfontaine, the 30.01.2013.

Marcel LAMBERT,
Director.

INSTITUT SCIENTIFIQUE DE SERVICE PUBLIC
Zoning A. Schweitzer, rue de la Platinerie
B-7340 COLFONTAINE (Wasmès)
Tél: ++ 32 65 610811 – Fax: ++ 32 65 610808
colfontaine@issep.be

This notification may only be reproduced in its entirety and without any change, eventual schedule included



SCHEDULE

PRODUCTION QUALITY ASSURANCE NOTIFICATION N° ISSeP09ATEX017/1

List of equipment or protective systems or components covered by this notification

- Development, design, manufacturing and sales of prefabricated cable accessories for medium and high voltage networks.

Extension of validity

Delivery date of the original notification: 27.03.2009.

Delivery date of this extension: 30.01.2013.

Expire date of this extension: 30.01.2016.

This notification may only be reproduced in its entirety and without any change, eventual schedule included

K400TB/G-ATEX INTERFACE C TEE CONNECTOR

Up to 12 kV
630 A (800 A)



6/10 (12) kV
6.35/11 (12) kV

Application

Separable tee shape connector (bolted type) designed to connect polymeric insulated cable to equipment (transformers, switchgear, motors, ...). Also connects cable to cable when using the appropriate mating parts.

Technical characteristics

- The thick conductive EPDM jacket provides a total safe to touch screen which ensures safety for personnel.
- Each separable connector is tested for AC withstand and partial discharge prior to leaving the factory.
- ATEX - Certification

Design

Separable connector comprising:

1. Conductive EPDM insert.
2. Conductive EPDM jacket.
3. Insulating EPDM layer.
4. Type C interface as described by CENELEC EN 50180 and 50181.
5. Conductor connector.
6. Basic insulating plug (with VD point).
7. Cable reducer.
8. Conductive rubber cap.
9. Clamping screw.
10. Earthing lead.

The screen break design enables cable outer sheath testing without removing or dismantling the connector.

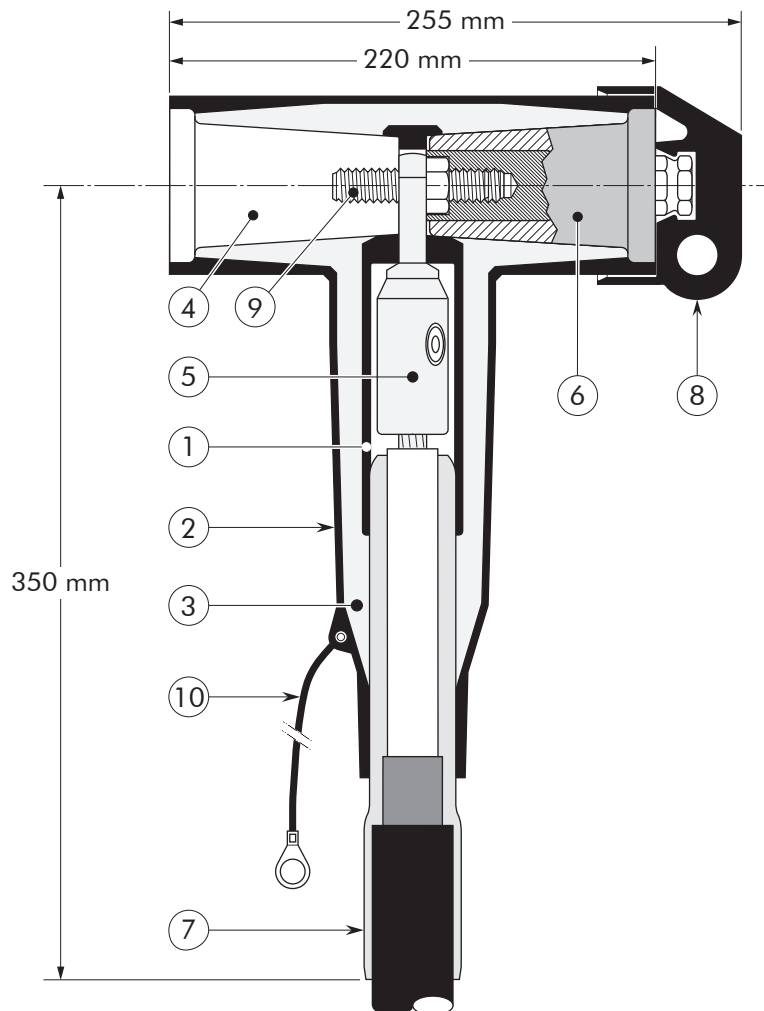

Specifications and standards

The 400TB separable connector meets the requirements of CENELEC HD 629.1 S1.

Certified for:

- II 2 G - Ex e IIC Gb and
- II 2 D - Ex tb IIIC Db IP6X

| Separable connector type | Voltage U_m (kV) | Current I_r (A) | Current I_r (A) | | Conductor sizes (mm ²) | |
|--------------------------|--------------------|-------------------|---|--|------------------------------------|-----|
| | | | When installed on an appropriate equipment bushing and when using a copper (-11-2) or a bolted (-12-5 or -14-5) conductor contact | | min | max |
| K400TB/G-ATEX | 12 | 630 | 800 | | 35 | 300 |

05/2013

Kit contents

The complete K400TB/G tee connector kit comprises the following components:

The kit also comprises silicone grease, field control mastic, installation instructions and crimp chart.

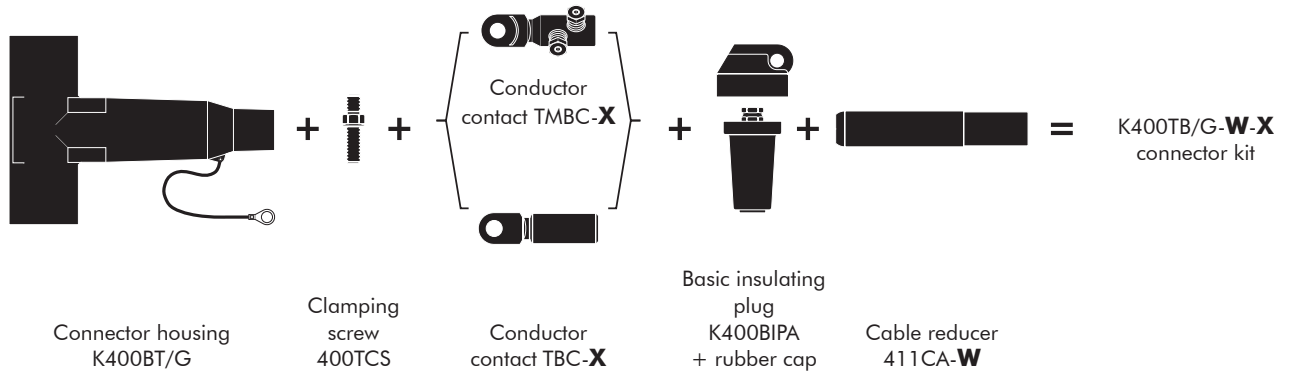

Ordering instructions

To order the tee connector, select the ordering part number which gives you the best centring of your core insulation diameter and substitute **X** using table X, according to your conductor size and type.

Table W

| Ordering part number | Dia. over core insulation (mm) | |
|----------------------|--------------------------------|------|
| | min | max |
| K400TB/G-11-X-ATEX | 12.0 | 17.5 |
| K400TB/G-15-X-ATEX | 16.0 | 22.0 |
| K400TB/G-19-X-ATEX | 20.0 | 26.5 |
| K400TB/G-22-X-ATEX | 23.5 | 31.0 |
| K400TB/G-25-X-ATEX | 26.5 | 32.5 |
| K400TB/G-27-X-ATEX | 28.5 | 37.5 |

Table X

| Conductor sizes (mm ²) | Aluminium conductor | | Aluminium and copper conductor | Copper conductor |
|------------------------------------|---------------------|--------------|--------------------------------|------------------|
| | DIN hexagonal | Deep indent | Bolted | DIN hexagonal |
| 35 | 35(K)M-10-2 | 35KM-10-1 | 16.95-14-5 | 35(K)M-11-2 |
| 50 | 50(K)M-10-2 | 50(K)M-10-1 | | 50.150-14-5 |
| 70 | 70(K)M-10-2 | 70(K)M-10-1 | 95.240-14-5 | |
| 95 | 95(K)M-10-2 | 95(K)M-10-1 | | 120.300-14-5 |
| 120 | 120(K)M-10-2 | 120(K)M-10-1 | | |
| 150 | 150(K)M-10-2 | 150(K)M-10-1 | | 150(K)M-11-2 |
| 185 | 185(K)M-10-2 | 185(K)M-10-1 | | 185(K)M-11-2 |
| 240 | 240(K)M-10-2 | 240(K)M-10-1 | | 240(K)M-11-2 |
| 300 | 300(K)M-10-2 | - | | 300(K)M-11-2 |

| | | | | | |
|---|---|---|---|---|---|
| | | | | | |
| For use with copper tape screened cables. Order: Kit MT. | For use with Alupec or C 33-226 cables. Please contact our representative. | For use with other cable types. Please contact our representative. | For applications outdoors and in humid climate. Order: +MWS. | For use in potentially explosive atmospheres (for 12 kV max). Add -/ATEX to part number. | When installed on an appropriate equipment bushing: 800 A continuously |

K430TB/G-ATEX INTERFACE C TEE CONNECTOR

**Up to 12 kV
630 A -1250 A**



**6/10 (12) kV
6.35/11 (12) kV**

Application

Separable tee shape connector (bolted type) designed to connect polymeric insulated cable to equipment (transformers, switchgear, motors, ...). Also connects cable to cable when using the appropriate mating parts.

Technical characteristics

- A thick conductive EPDM jacket provides a total safe to touch screen.
- Each separable connector is tested for AC withstand and partial discharge prior to leaving the factory.
- ATEX - Certification

Design

Separable connector comprising:

1. Conductive EPDM insert.
2. Conductive EPDM jacket.
3. Insulating EPDM layer moulded between the insert and the jacket.
4. Type C interface as described by CENELEC EN 50180 and 50181.
5. Conductor connector.
6. Basic insulating plug (with VD point).
7. Cable reducer.
8. Conductive rubber cap.
9. Clamping screw.
10. Earthing lead.

The screen break design enables cable outer sheath testing without removing or dismantling the connector.

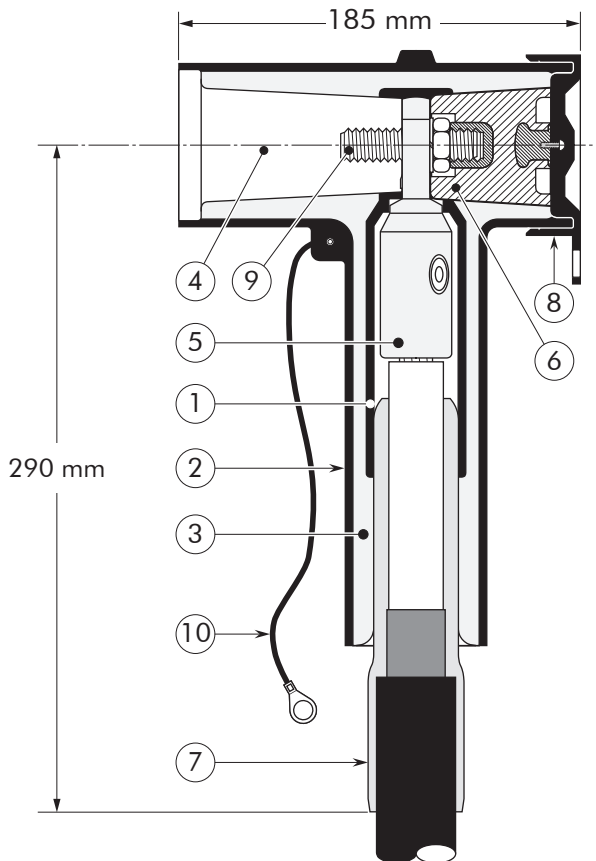

Specifications and standards

The 430TB separable connector meets the requirements of CENELEC HD 629.1.

Certified for:

- II 2 G - Ex e IIC Gb and
- II 2 D - Ex tb IIIC Db IP6X

| Separable connector type | Voltage U_m (kV) | Current I_r (A) | Current I_r (A) When using a copper (-11-2) or a bolted (14-5) conductor contact and when installed on an appropriate equipment bushing | Conductor sizes (mm ²) | |
|--------------------------|--------------------|-------------------|--|------------------------------------|-----|
| | | | | min | max |
| K430TB/G-ATEX | 12 | 630 | 1250 | 35 | 300 |

05/2013

Kit contents

The complete K430TB/G tee connector kit comprises 3 x the following components:

The kit also comprises silicone grease, field control mastic, installation rod, installation instructions and crimp chart.

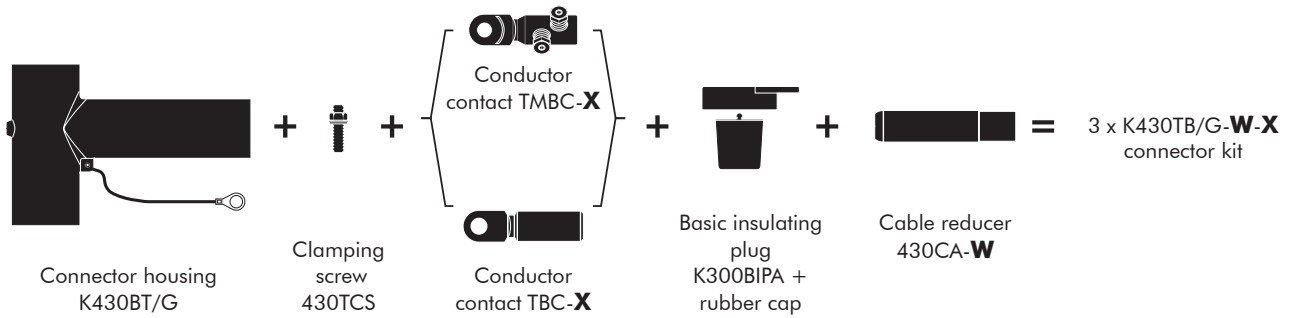

Ordering instructions

To order the tee connector, select the ordering part number which gives you the best centring of your core insulation diameter and substitute **X** using table X, according to your conductor size and type.

Table W

| Ordering part number | Dia. over core insulation (mm) | |
|------------------------|--------------------------------|------|
| | min | max |
| 3 x K430TB/G-11-X-ATEX | 12.0 | 17.5 |
| 3 x K430TB/G-16-X-ATEX | 17.0 | 23.5 |
| 3 x K430TB/G-18-X-ATEX | 19.0 | 32.6 |
| 3 x K430TB/G-27-X-ATEX | 28.5 | 37.5 |

Table X

| Conductor sizes (mm ²) | Aluminium conductor | | Aluminium and copper conductor | Copper conductor |
|------------------------------------|---------------------|--------------|--------------------------------|------------------|
| | DIN hexagonal | Deep indent | Bolted | DIN hexagonal |
| 35 | 35(K)M-10-2 | 35KM-10-1 | 16.95-14-5 | 35(K)M-11-2 |
| 50 | 50(K)M-10-2 | 50(K)M-10-1 | | 50.150-14-5 |
| 70 | 70(K)M-10-2 | 70(K)M-10-1 | 95.240-14-5 | |
| 95 | 95(K)M-10-2 | 95(K)M-10-1 | | 120.300-14-5 |
| 120 | 120(K)M-10-2 | 120(K)M-10-1 | | |
| 150 | 150(K)M-10-2 | 150(K)M-10-1 | | 150(K)M-11-2 |
| 185 | 185(K)M-10-2 | 185(K)M-10-1 | | 185(K)M-11-2 |
| 240 | 240(K)M-10-2 | 240(K)M-10-1 | | 240(K)M-11-2 |
| 300 | 300(K)M-10-2 | - | | 300(K)M-11-2 |

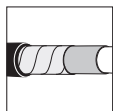

For use with copper tape screened cables.
Order: Kit MT.



For use in potentially explosive atmospheres (for 12 kV max).
Add -/ATEX to part number.

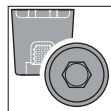

Up to 24 kV this product can also be installed using a 300BIPR (without VD point) Order: BIPR.



For use with other cable types. Please contact our representative.



For applications outdoors and in humid climate.
Order: +MWS.



This product can also be installed using a 411 CA. Please contact our representative.

K440TB/G-ATEX INTERFACE C TEE CONNECTOR

Up to 12 kV
630 A (1250 A)



6/10 (12) kV
6.35/11 (12) kV

Application

Separable tee shape connector (bolted type) designed to connect polymeric insulated cable to equipment (transformers, switchgear, motors, ...). Also connects cable to cable when using the appropriate mating parts.

Technical characteristics

- The thick conductive EPDM jacket provides a total safe to touch screen which ensures safety for personnel.
- Each separable connector is tested for AC withstand and partial discharge prior to leaving the factory.
- ATEX - Certification

Design

Separable connector comprising:

1. Conductive EPDM insert.
2. Conductive EPDM jacket.
3. Insulating EPDM layer moulded between the insert and the jacket.
4. Type C - 630 A interface as described by CENELEC EN 50180 and 50181.
5. Conductor connector.
6. Basic insulating plug (with VD point).
7. Cable reducer.
8. Conductive rubber cap.
9. Clamping screw.
10. Earthing lead.

The screen break design enables cable outer sheath testing without removing or dismantling the connector.

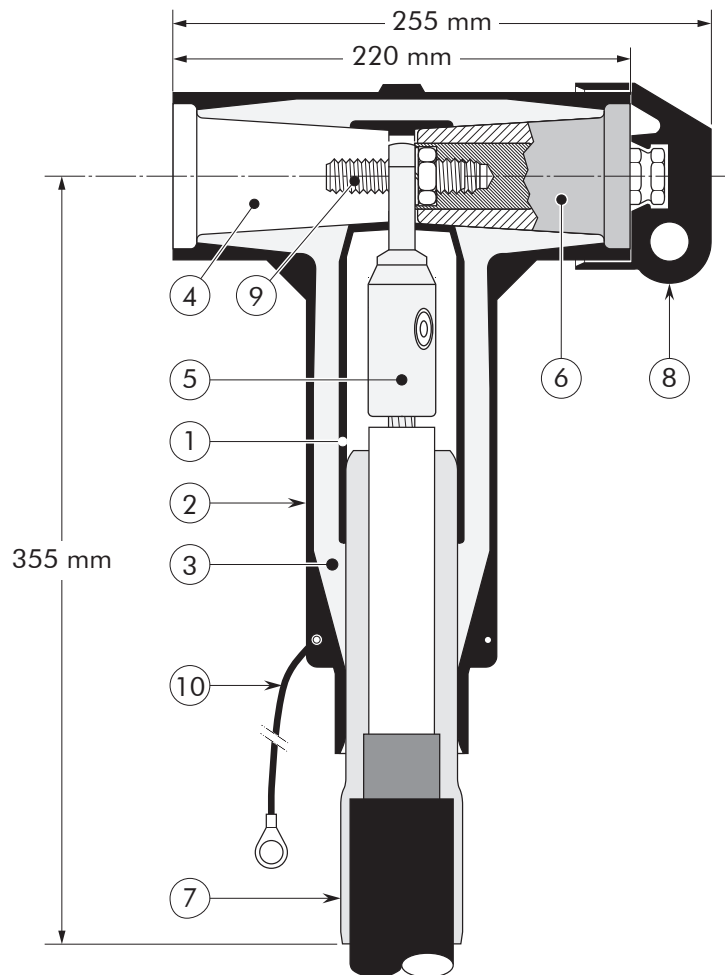

Specifications and standards

The 440TB separable connector meets the requirements of CENELEC HD 629.1.

Certified for:

- II 2 G - Ex e IIC Gb and
- II 2 D - Ex tb IIIC Db IP6X

| Separable connector type | Voltage U_m (kV) | Current I_r (A) | Current I_r (A) When installed on an appropriate equipment bushing | Conductor sizes (mm ²) | |
|--------------------------|--------------------|-------------------|---|------------------------------------|-----|
| | | | | min | max |
| K440TB/G-ATEX | 12 | 630 | 1250 | 185 | 630 |

05/2013

Kit contents

The complete K440TB/G tee connector kit comprises the following components:

The kit also comprises silicone grease, field control mastic, installation instructions and crimp chart.

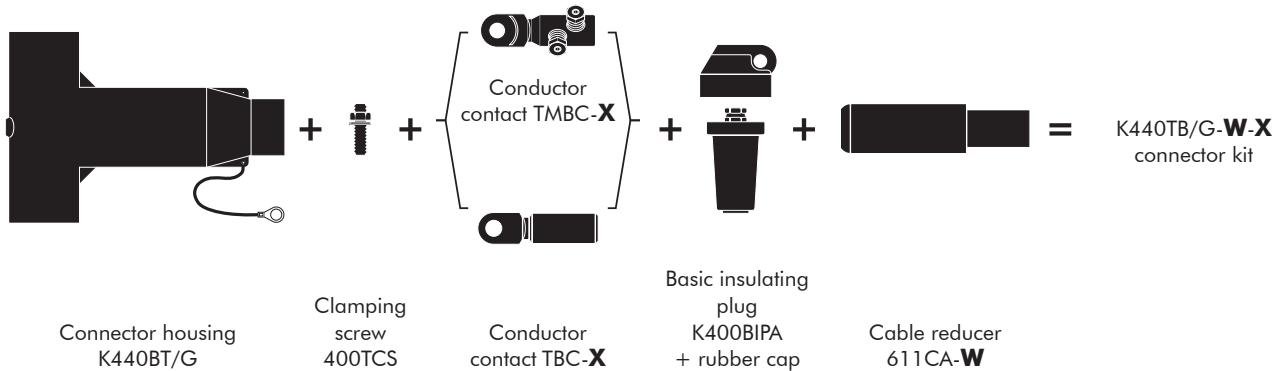

Ordering instructions

To order the tee connector, select the ordering part number which gives you the best centring of your core insulation diameter and substitute **X** using table X, according to your conductor size and type.

Table W

| Ordering part number | Dia. over core insulation (mm) | |
|-----------------------------|--------------------------------|------|
| | min | max |
| K440TB/G-22- X -ATEX | 23.5 | 31.0 |
| K440TB/G-27- X -ATEX | 28.5 | 37.5 |
| K440TB/G-32- X -ATEX | 34.0 | 42.5 |
| K440TB/G-37- X -ATEX | 39.0 | 48.5 |
| K440TB/G-43- X -ATEX | 45.5 | 56.0 |

Table X

| Conductor sizes (mm ²) | Aluminium conductor | | Aluminium and copper conductor | Copper conductor |
|------------------------------------|---------------------|-------------|--------------------------------|------------------|
| | DIN hexagonal | Deep indent | Bolted | DIN hexagonal |
| 185 | 185(K)M-12-2 | 185KM-12-1 | 185.400-14-5 | 185(K)M-11-2 |
| 240 | 240(K)M-12-2 | 240KM-12-1 | | 400.630-14-5 |
| 300 | 300(K)M-12-2 | 300KM-12-1 | | 300(K)M-11-2 |
| 400 | 400(K)M-12-2 | 400KM-12-1 | | 400(K)M-11-2 |
| 500 | 500(K)M-12-2 | 500KM-12-1 | | 500(K)M-11-2 |
| 630 | - | 630KM-12-1 | | 630(K)M-11-2 |

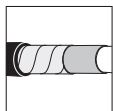

For use with copper tape screened cables. Order: Kit MT.

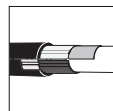

For use with Alupe or C 33-226 cables. Please contact our representative.



For use with other cable types. Please contact our representative.



For applications outdoors and in humid climate. Order: +MWS.



For use in potentially explosive atmospheres (for 12 kV max). Add -/ATEX to part number.



When installed on an appropriate equipment bushing: 1250 A continuously

K484TB/G-ATEX

INTERFACE C

TEE CONNECTOR

Up to 12 kV
630 A - 1250 A



6/10 (12) kV
6.35/11 (12) kV

Application

Separable tee shape connector (bolted type) designed to connect polymeric insulated cable to equipment (transformers, switchgear, motors, ...). Also connects cable to cable when using the appropriate mating parts.

Technical characteristics

- The thick conductive EPDM jacket provides a total safe to touch screen which ensures safety for personnel.
- Each separable connector is tested for AC withstand and partial discharge prior to leaving the factory.
- ATEX - Certification

Design

Separable connector comprising:

1. Conductive EPDM insert.
2. Conductive EPDM jacket.
3. Insulating EPDM layer moulded between the insert and the jacket.
4. Type C - interface as described by CENELEC EN 50180 and 50181.
5. Conductor connector.
6. Basic insulating plug (with VD point).
7. Cable reducer.
8. Conductive rubber cap.
9. Clamping screw.
10. Earthing lead.

The screen break design enables cable outer sheath testing without removing or dismantling the connector.

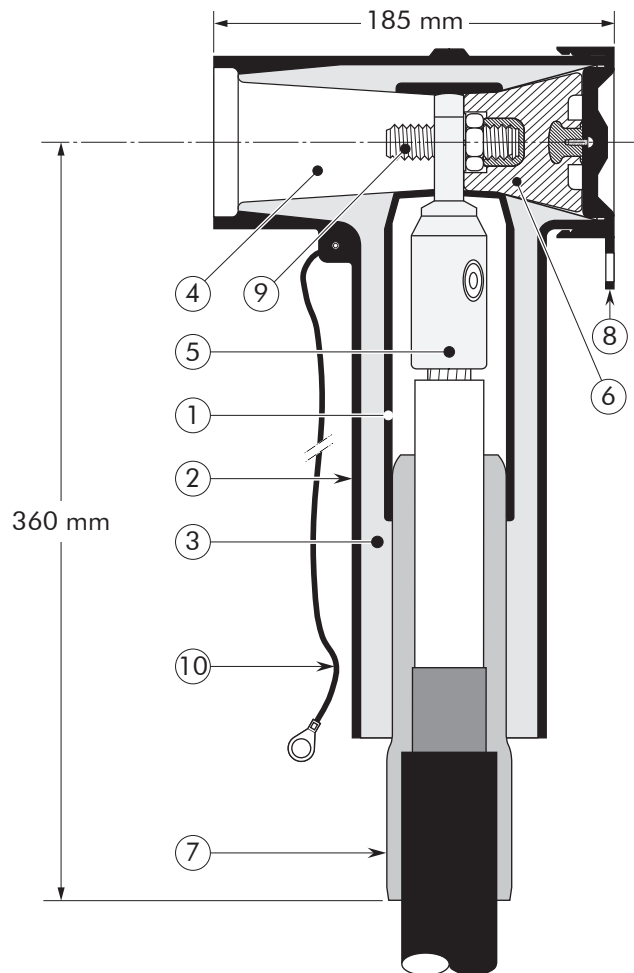

Specifications and standards

The 484TB separable connector meets the requirements of CENELEC HD 629.1.

Certified for:

- II 2 G - Ex e IIC Gb and
- II 2 D - Ex tb IIIC Db IP6X

| Separable connector type | Voltage U_m (kV) | Current I_r (A) When installed on an appropriate equipment bushing | Conductor sizes (mm ²) | |
|--------------------------|--------------------|---|------------------------------------|-----|
| | | | min | max |
| K484TB/G-ATEX | 12 | 1250 | 50 | 630 |

05/2013

Kit contents

The complete K484TB/G tee connector kit comprises 3x the following components:

The kit also comprises silicone grease, field control mastic, gloves, roll adhesive tape, installation instructions and crimp chart.

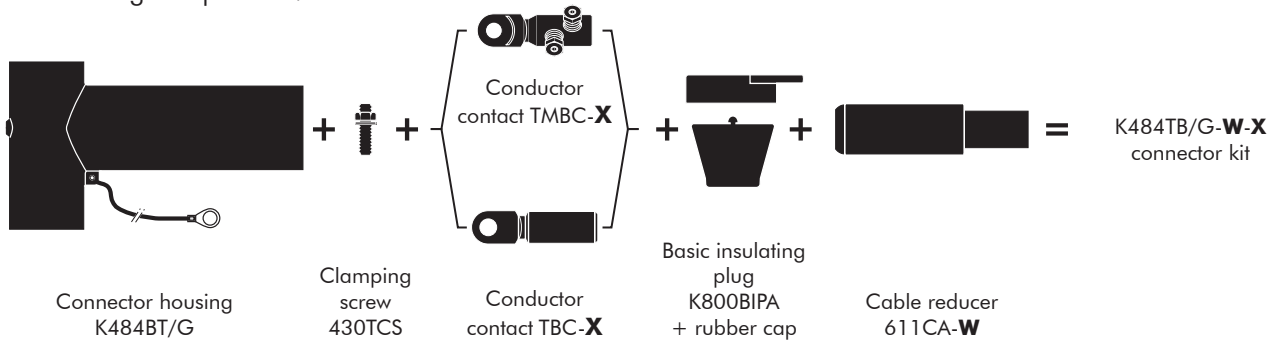

Ordering instructions

To order the tee connector, select the ordering part number which gives you the best centring of your core insulation diameter and substitute **X** using table X, according to your conductor size and type.

Table W

| Ordering part number | Dia. over core insulation (mm) | |
|------------------------|--------------------------------|------|
| | min | max |
| 3 x K484TB/G-15-X-ATEX | 16.0 | 22.0 |
| 3 x K484TB/G-19-X-ATEX | 20.0 | 26.5 |
| 3 x K484TB/G-22-X-ATEX | 23.5 | 31.0 |
| 3 x K484TB/G-27-X-ATEX | 28.5 | 37.5 |
| 3 x K484TB/G-32-X-ATEX | 34.0 | 42.5 |
| 3 x K484TB/G-37-X-ATEX | 39.0 | 48.5 |
| 3 x K484TB/G-43-X-ATEX | 45.5 | 56.0 |

Table X

| Conductor sizes (mm ²) | Aluminium conductor | | Aluminium and copper conductor | Copper conductor |
|------------------------------------|---------------------|-------------|--|------------------|
| | DIN hexagonal | Deep indent | Bolted | DIN hexagonal |
| 35 | 35(K)M-12-2 | 35KM-12-1 | 16.95-14-5 50.150-14-5 95.240-14-5 120.300-14-5 185.400-14-5 400.630-14-5 | 35(K)M-11-2 |
| 50 | 50(K)M-12-2 | 50KM-12-1 | | 50(K)M-11-2 |
| 70 | 70(K)M-12-2 | 70KM-12-1 | | 70(K)M-11-2 |
| 95 | 95(K)M-12-2 | 95KM-12-1 | | 95(K)M-11-2 |
| 120 | 120(K)M-12-2 | 120KM-12-1 | | 120(K)M-11-2 |
| 150 | 150(K)M-12-2 | 150KM-12-1 | | 150(K)M-11-2 |
| 185 | 185(K)M-12-2 | 185KM-12-1 | | 185(K)M-11-2 |
| 240 | 240(K)M-12-2 | 240KM-12-1 | | 240(K)M-11-2 |
| 300 | 300(K)M-12-2 | 300KM-12-1 | | 300(K)M-11-2 |
| 400 | 400(K)M-12-2 | 400KM-12-1 | | 400(K)M-11-2 |
| 500 | 500(K)M-12-2 | 500KM-12-1 | | 500(K)M-11-2 |
| 630 | - | 630KM-12-1 | | 630(K)M-11-2 |

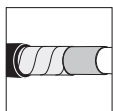

For use with copper tape screened cables. Order: Kit MT.

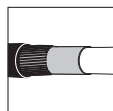

For use with copper wire screened cables. No earthing device is necessary.

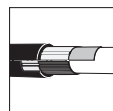

For use with Alupe or C 33-226 cables. Please contact our representative.



For use with other cable types. Please contact our representative.



For applications outdoors and in humid climate. Order: +MWS.



For use in potentially explosive atmospheres (for 12 kV max). Add -/ATEX to part number.

K300PBM/G-ATEX COUPLING CONNECTOR FOR 430TB

**Up to 12 kV
630A - 1250 A**



**6/10 (12) kV
6.35/11 (12) kV**

Application

Separable coupling connector (bolted type) for dual cable arrangement. It has been designed to be used with 430TB separable tee connector.

Technical characteristics

- A thick conductive EPDM jacket provides a total safe to touch screen.
- Each separable connector is tested for AC withstand and partial discharge prior to leaving the factory.
- ATEX - Certification

Design

1. Interface designed to fit 430TB connector.
2. Bus for 300PBM.
3. Conductive EPDM insert.
4. Insulating EPDM layer moulded between the insert and the jacket.
5. Conductive EPDM jacket.
6. Conductive EPDM cap.
7. Basic insulating plug (with VD point).
8. Conductor connector (hexagonal crimping, deep indent crimping or bolted).
9. Cable reducer.
10. Earthing lead.

The screen break design enables cable outer sheath testing without removing or dismantling the connector.

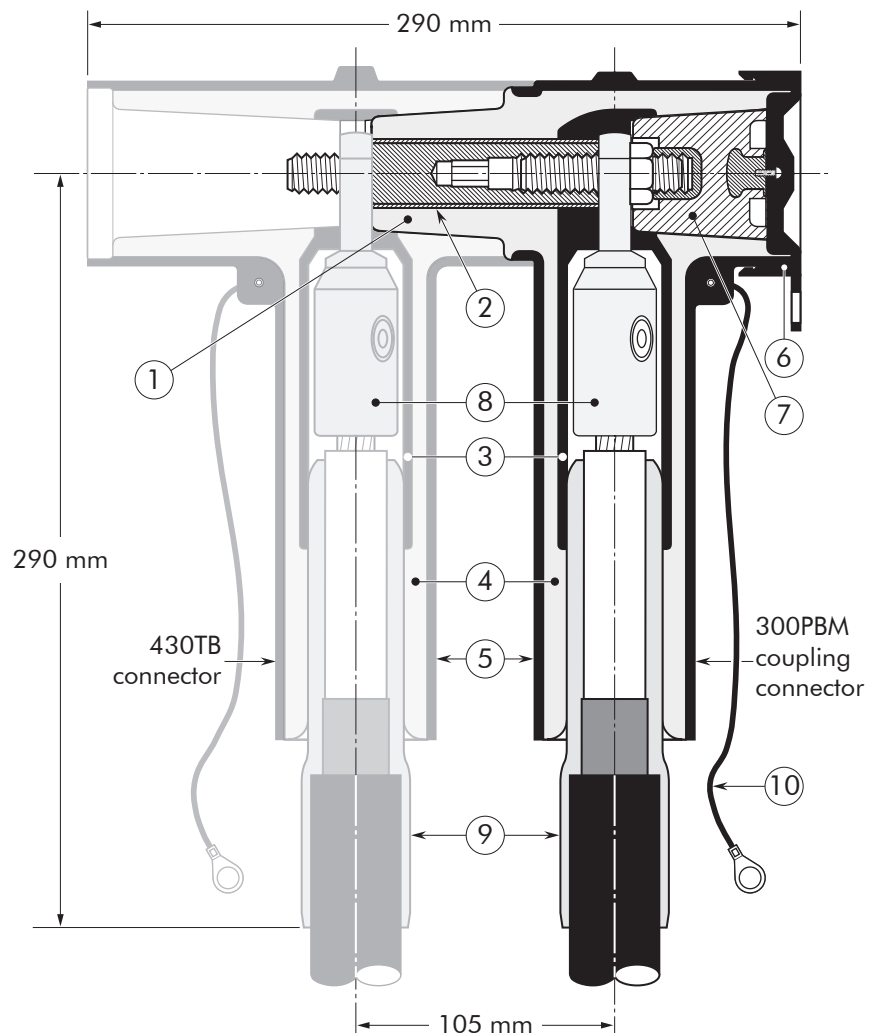

Specifications and standards

The 300PBM coupling connector meets the requirements of CENELEC HD 629.1.

Certified for:

- II 2 G - Ex e IIC Gb and
- II 2 D - Ex tb IIIC Db IP6X

| Separable connector type | Voltage U_m (kV) | Current I_r (A) | Current I_r (A) When using a copper (-11-2) or a bolted (14-5) conductor contact and when installed on an appropriate equipment bushing | Conductor sizes (mm ²) | |
|--------------------------|--------------------|-------------------|--|------------------------------------|-----|
| | | | | min | max |
| K300PBM/G-ATEX | 12 | 630 | 1250 | 35 | 300 |

05/2013

Kit contents

The complete K300PBM/G coupling connector kit comprises 3 x the following components:

The kit also comprises silicone grease, field control mastic, installation rod, installation instructions and crimp chart.

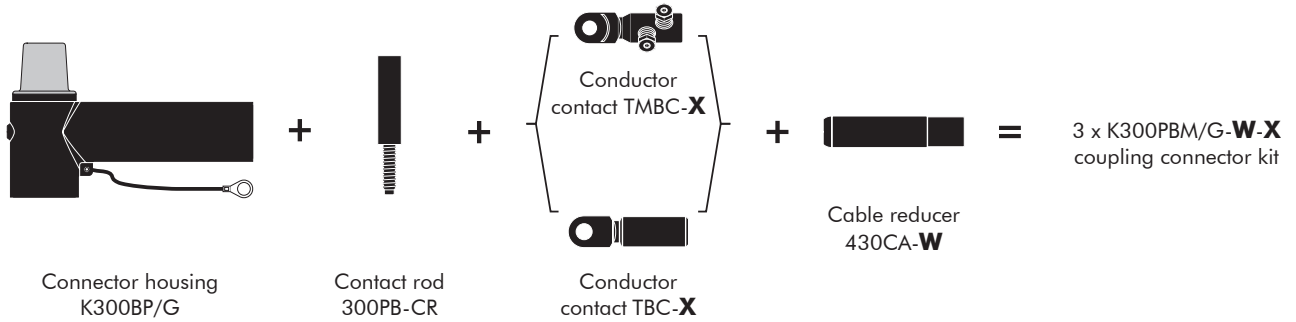

Ordering instructions

To order the coupling connector, select the ordering part number which gives you the best centring of your core insulation diameter and substitute **X** using table X, according to your conductor size and type.

Table W

| Ordering part number | Dia. over core insulation (mm) | |
|----------------------------------|--------------------------------|------|
| | min | max |
| 3 x K300PBM/G-11- X -ATEX | 12.0 | 17.5 |
| 3 x K300PBM/G-16- X -ATEX | 17.0 | 23.5 |
| 3 x K300PBM/G-18- X -ATEX | 19.0 | 32.6 |
| 3 x K300PBM/G-27- X -ATEX | 28.5 | 37.5 |

Table X

| Conductor sizes (mm ²) | Aluminium conductor | | Aluminium and copper conductor | Copper conductor |
|------------------------------------|---------------------|--------------|--------------------------------|------------------|
| | DIN hexagonal | Deep indent | Bolted | DIN hexagonal |
| 35 | 35(K)M-10-2 | 35KM-10-1 | 16.95-14-5 | 35(K)M-11-2 |
| 50 | 50(K)M-10-2 | 50(K)M-10-1 | | 50.150-14-5 |
| 70 | 70(K)M-10-2 | 70(K)M-10-1 | 95.240-14-5 | |
| 95 | 95(K)M-10-2 | 95(K)M-10-1 | | 120.300-14-5 |
| 120 | 120(K)M-10-2 | 120(K)M-10-1 | | |
| 150 | 150(K)M-10-2 | 150(K)M-10-1 | | 150(K)M-11-2 |
| 185 | 185(K)M-10-2 | 185(K)M-10-1 | | 185(K)M-11-2 |
| 240 | 240(K)M-10-2 | 240(K)M-10-1 | | 240(K)M-11-2 |
| 300 | 300(K)M-10-2 | - | | 300(K)M-11-2 |

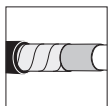

For use with copper tape screened cables. Order: Kit MT.



For use in potentially explosive atmospheres (for 12 kV max). Add -/ATEX to part number.

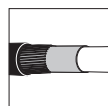

For use with copper wire screened cables. No earthing device is necessary.



For use with other cable types. Please contact our representative.



For outdoor applications. Order: +MWS.



This product can also be installed using a 411 CA. Please contact our representative.

K804PB/G-ATEX COUPLING CONNECTOR FOR 484TB/G

Up to 12 kV
1250 A



6/10 (12) kV
6.35/11 (12) kV

Application

Separable coupling connector (bolted type) for dual cable arrangement. It has been designed to be used with 484TB separable tee connectors.

Technical characteristics

- A thick conductive EPDM jacket provides a total safe to touch screen.
- Each separable connector is tested for AC withstand and partial discharge prior to leaving the factory.
- ATEX - Certification

Design

1. Interface designed to fit 484TB connector.
2. Bus for 804PB.
3. Conductor connector (hexagonal crimping, deep indent crimping or bolted).
4. Conductive EPDM insert.
5. Conductive EPDM jacket.
6. Insulating EPDM layer moulded between the insert and the jacket.
7. Cable reducer.
8. Conductive EPDM cap.
9. Basic insulating plug (with VD point).
10. Earth lead.

The screen break design enables cable outer sheath testing without removing or dismantling the connector.

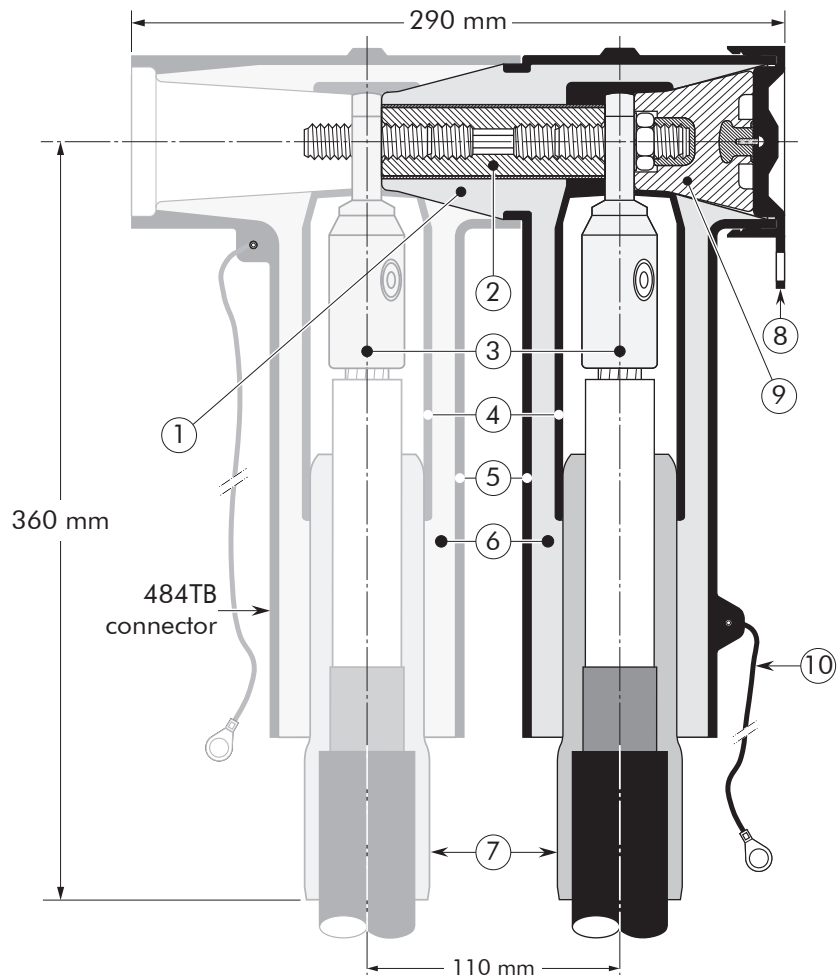

Specifications and standards

The 804PB coupling connector meets the requirements of CENELEC HD 629.1.

Certified for:

- II 2 G - Ex e IIC Gb and
- II 2 D - Ex tb IIC Db IP6X

| Separable connector type | Voltage U_m (kV) | Current I_r (A) | Conductor sizes (mm ²) | |
|--------------------------|--------------------|-------------------|------------------------------------|-----|
| | | | min | max |
| K804PB/G-ATEX | 12 | 1250 | 50 | 630 |

05/2013

Kit contents

The complete K804PB/G coupling connector kit comprises 3 x the following components:

The kit also comprises silicone grease, field control mastic, gloves, roll adhesive tape, installation instructions and crimp chart.

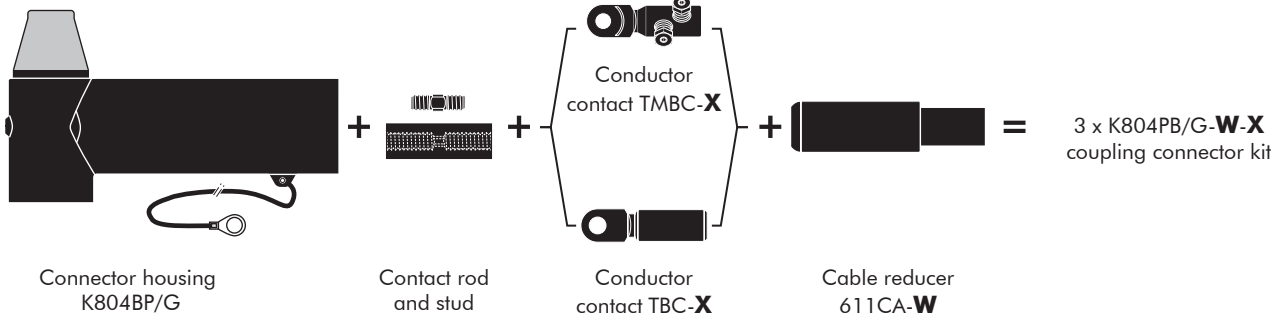

Ordering instructions

To order the coupling connector, select the ordering part number which gives you the best centring of your core insulation diameter and substitute **X** using table X, according to your conductor size and type.

Table W

| Ordering part number | Dia. over core insulation (mm) | |
|---------------------------------|--------------------------------|------|
| | min | max |
| 3 x K804PB/G-15- X -ATEX | 16.0 | 22.0 |
| 3 x K804PB/G-19- X -ATEX | 20.0 | 26.5 |
| 3 x K804PB/G-22- X -ATEX | 23.5 | 31.0 |
| 3 x K804PB/G-27- X -ATEX | 28.5 | 37.5 |
| 3 x K804PB/G-32- X -ATEX | 34.0 | 42.5 |
| 3 x K804PB/G-37- X -ATEX | 39.0 | 48.5 |
| 3 x K804PB/G-43- X -ATEX | 45.5 | 56.0 |

Table X

| Conductor sizes (mm ²) | Aluminium conductor | | Aluminium and copper conductor | Copper conductor |
|------------------------------------|---------------------|-------------|--|------------------|
| | DIN hexagonal | Deep indent | Bolted | DIN hexagonal |
| 35 | 35(K)M-12-2 | 35KM-12-1 | 16.95-14-5 50.150-14-5 95.240-14-5 120.300-14-5 185.400-14-5 400.630-14-5 | 35(K)M-11-2 |
| 50 | 50(K)M-12-2 | 50KM-12-1 | | 50(K)M-11-2 |
| 70 | 70(K)M-12-2 | 70KM-12-1 | | 70(K)M-11-2 |
| 95 | 95(K)M-12-2 | 95KM-12-1 | | 95(K)M-11-2 |
| 120 | 120(K)M-12-2 | 120KM-12-1 | | 120(K)M-11-2 |
| 150 | 150(K)M-12-2 | 150KM-12-1 | | 150(K)M-11-2 |
| 185 | 185(K)M-12-2 | 185KM-12-1 | | 185(K)M-11-2 |
| 240 | 240(K)M-12-2 | 240KM-12-1 | | 240(K)M-11-2 |
| 300 | 300(K)M-12-2 | 300KM-12-1 | | 300(K)M-11-2 |
| 400 | 400(K)M-12-2 | 400KM-12-1 | | 400(K)M-11-2 |
| 500 | 500(K)M-12-2 | 500KM-12-1 | | 500(K)M-11-2 |
| 630 | - | 630KM-12-1 | 630(K)M-11-2 | |

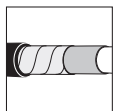

For use with copper tape screened cables. Order: Kit MT.

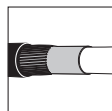

For use with copper wire screened cables. No earthing device is necessary.

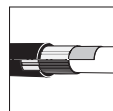

For use with Alupec C 33-226 cables. Please contact our representative.



For use with other cable types. Please contact our representative.



For applications outdoors and in humid climate. Order: +MWS.



For use in potentially explosive atmospheres (for 12 kV max). Add -/ATEX to part number.

400PB-XSA-ATEX INTERFACE C SURGE ARRESTER

Up to 12 kV



6/10 (12) kV
6.35/11 (12) kV

Application

Surge arrester designed to protect medium voltage components, including transformers, equipment, cable and accessories from high voltage surges resulting from lightning or switching.

Technical characteristics

- This surge arrester is a metal oxide varistor surge arrester in an elbow configuration.
- Each arrester is tested for AC withstand, partial discharge and critical voltage prior to leaving the factory.
- ATEX - Certification

Design

Surge arrester comprising:

1. Conductive EPDM insert.
2. Conductive EPDM jacket.
3. Insulating EPDM layer moulded between the insert and the jacket.
4. Contact rod.
5. Earthing lead.
6. Earth connection.
7. Steel cap.
8. Metal oxide valve elements.
9. Type C interface as described by CENELEC EN 50180 and 50181.

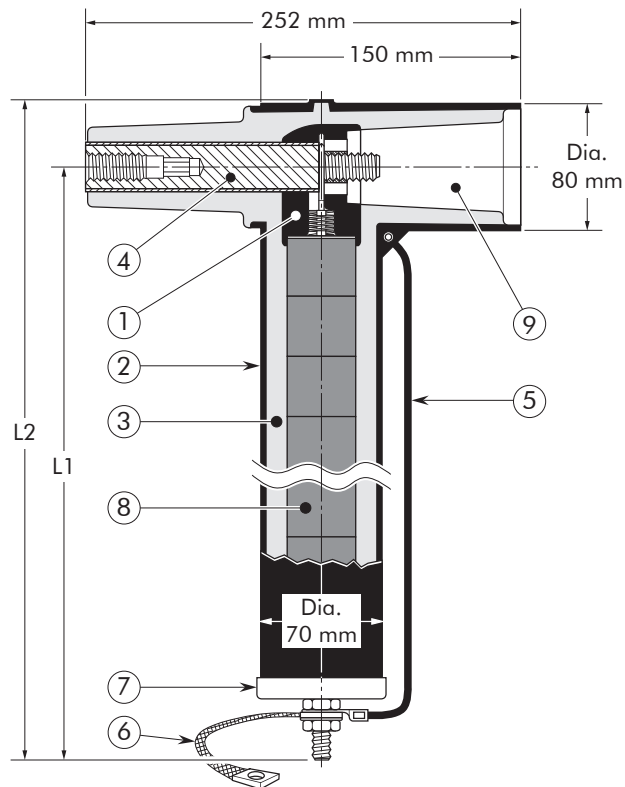

Specifications and standards

The 400PB-XSA surge arresters meet the test requirements of IEC 60099-4.

Certified for:

- II 2 G - Ex e IIC Gb and
- II 2 D - Ex tb IIIC Db IP6X

| Surge arrester type | Nominal discharge current I_n (kA) | Rated voltage U_r (kV) | Max. continuous operating voltage U_c (kV) | Dimensions (mm) | |
|---------------------|--------------------------------------|--------------------------|--|-----------------|-----|
| | | | | L1 | L2 |
| 400PB-5SA-15L-ATEX | 5 | 15 | 12.0 | 250 | 290 |
| 400PB-5SA-18L-ATEX | 5 | 18 | 14.4 | 250 | 290 |
| 400PB-5SA-22L-ATEX | 5 | 22 | 17.6 | 350 | 290 |
| 400PB-10SA-15N-ATEX | 10 | 15 | 12.0 | 250 | 290 |
| 400PB-10SA-18N-ATEX | 10 | 18 | 14.4 | 250 | 290 |
| 400PB-10SA-22N-ATEX | 10 | 22 | 17.6 | 250 | 290 |

300SA-ATEX SURGE ARRESTER FOR 430TB CONNECTOR

Up to 12 kV



6/10 (12) kV
6.35/11 (12) kV

Application

Surge arrester designed to protect 12 kV class components, including transformers, equipment, cable and accessories from high voltage surges resulting from lightning or switching. It has been designed to be used with the 430TB and 300PB separable connectors.

Technical characteristics

- This surge arrester is a metal oxide varistor surge arrester in an elbow configuration.
- Each arrester is tested for AC withstand, partial discharge and critical voltage prior to leaving the factory.
- ATEX - Certification

Design

Surge arrester comprising:

1. Interface designed to fit the 430TB/300PB connector.
2. Conductive EPDM insert.
3. Conductive EPDM jacket.
4. Insulating EPDM layer moulded between the insert and the jacket.
5. Receptacle for contact rod.
6. Metal oxide valve elements.
7. Steel cap.
8. Earth connection.
9. Earth lead.

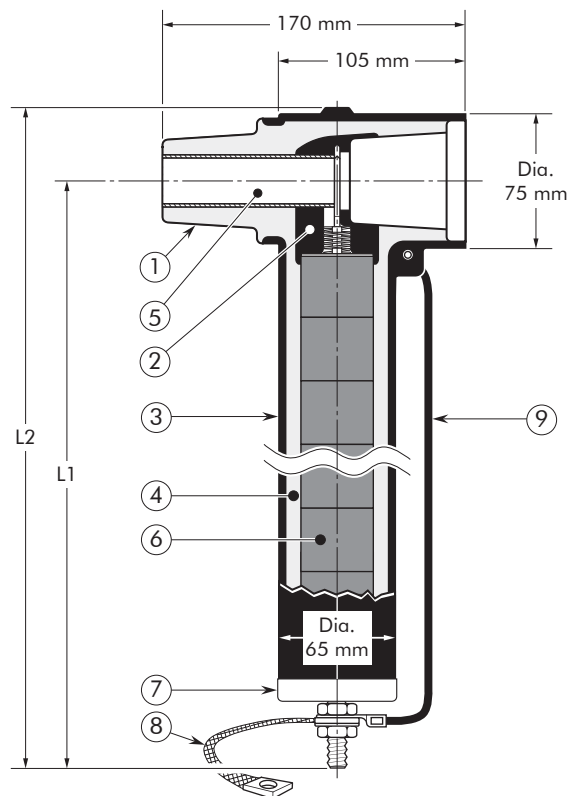

Specifications and standards

The 300SA surge arresters meet the test requirements of IEC 60099-4.

Certified for:

- II 2 G - Ex e IIC Gb and
- II 2 D - Ex tb IIIC Db IP6X

| Surge arrester type | Nominal discharge current I_n (kA) | Rated voltage U_r (kV) | Max. continuous operating voltage U_c (kV) | Dimensions (mm) | |
|---------------------|--------------------------------------|--------------------------|--|-----------------|-----|
| | | | | L1 | L2 |
| 300SA-10-6N-ATEX | 10 | 6 | 4.8 | 250 | 290 |
| 300SA-10-9N-ATEX | 10 | 9 | 7.2 | 250 | 290 |
| 300SA-10-12N-ATEX | 10 | 12 | 9.6 | 250 | 290 |
| 300SA-10-15N-ATEX | 10 | 15 | 12.0 | 250 | 290 |
| 300SA-10-18N-ATEX | 10 | 18 | 14.4 | 250 | 290 |
| 300SA-10-22N-ATEX | 10 | 22 | 17.6 | 250 | 290 |

800SA-ATEX SURGE ARRESTER FOR 484TB CONNECTOR

Up to 12 kV



6/10 (12) kV
6.35/11 (12) kV

Application

Surge arrester designed to protect 12 kV class components, including transformers, equipment, cable and accessories from high voltage surges resulting from lightning or switching. It has been designed to be used with the 484TB and 804PB separable connectors.

Technical characteristics

- This surge arrester is a metal oxide varistor surge arrester in an elbow configuration.
- Each arrester is tested for AC withstand, partial discharge and critical voltage prior to leaving the factory.

Design

Surge arrester comprising:

1. Interface designed to fit the 484TB and 804PB connector.
2. Conductive EPDM insert.
3. Conductive EPDM jacket.
4. Insulating EPDM layer moulded between the insert and the jacket.
5. Receptacle for contact rod.
6. Metal oxide valve elements.
7. Steel cap.
8. Earth connection.
9. Earth lead.

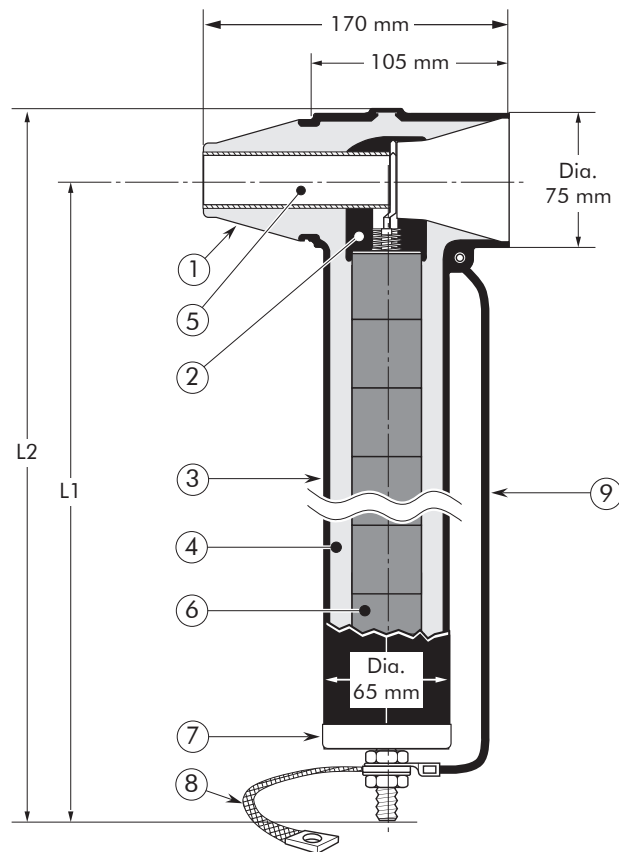

Specifications and standards

The 800SA surge arresters meet the test requirements of IEC 60099-4.

Certified for:

- II 2 G - Ex e IIC Gb and
- II 2 D - Ex tb IIIC Db IP6X

| Surge arrester type | Nominal discharge current I_n (kA) | Rated voltage U_r (kV) | Max. continuous operating voltage U_c (kV) | Dimensions (mm) | |
|---------------------|--------------------------------------|--------------------------|--|-----------------|-----|
| | | | | L1 | L2 |
| 800SA-10-15N-ATEX | 10 | 15 | 12.0 | 250 | 290 |
| 800SA-10-18N-ATEX | 10 | 18 | 14.4 | 250 | 290 |
| 800SA-10-22N-ATEX | 10 | 22 | 17.6 | 250 | 290 |

05/2013

K400AR-3-ATEX

INTERFACE C1

EQUIPMENT BUSHING

Up to 12 kV - 630 A

Application

For use in equipment insulated with oil fluid, typically for transformers, switchgear, capacitors...

Technical characteristics

- Each bushing is tested for AC withstand and partial discharge prior to leaving the factory.
- ATEX - Certification



Specifications and standards

The bolted type equipment bushings 400AR-3 are moulded epoxy insulated parts and meet the requirements of CENELEC EN 50180 and IEC 60137.

Certified for:

- II 2 G - Ex e IIC Gb and
- II 2 D - Ex tb IIIC Db IP6X

Ordering instructions

To order the equipment bushing, specify the type. The bushings can be supplied with an earth jumper (/J). E.g. K400AR-3/J-ATEX.

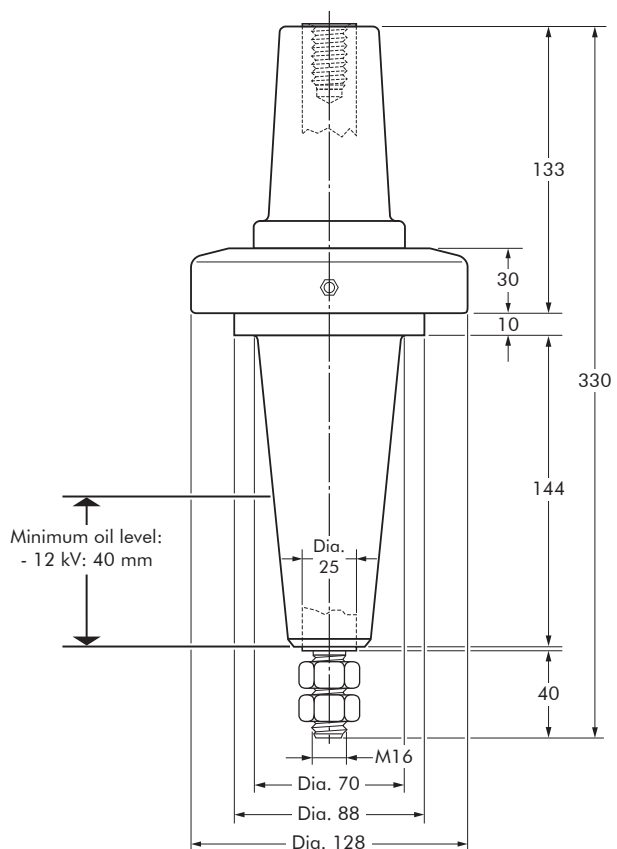

In mm.

| Equipment bushing type | Voltage U_0/U (kV) | Current I_r (A) |
|------------------------|----------------------|-------------------|
| K400AR-3-ATEX | 6,35/11 | 630 |

K400AR-4-ATEX INTERFACE C2 EQUIPMENT BUSHING

Up to 12 kV - 1250 A

Application

For use in equipment insulated with oil fluid, typically for transformers, switchgear, capacitors...

Technical characteristics

- Each bushing is tested for AC withstand and partial discharge prior to leaving the factory.
- ATEX - Certification



Specifications and standards

The bolted type equipment bushings 400AR-4 are moulded epoxy insulated parts and meet the requirements of CENELEC EN 50180 and IEC 60137.

Certified for:

- II 2 G - Ex e IIC Gb and
- II 2 D - Ex tb IIIC Db IP6X

Ordering instructions

To order the equipment bushing, specify the type. The bushings can be supplied with an earth jumper (/J) or an earth plate (/GS). This earth connection must be specified when ordering. E.g. K400AR-4/GS-ATEX.

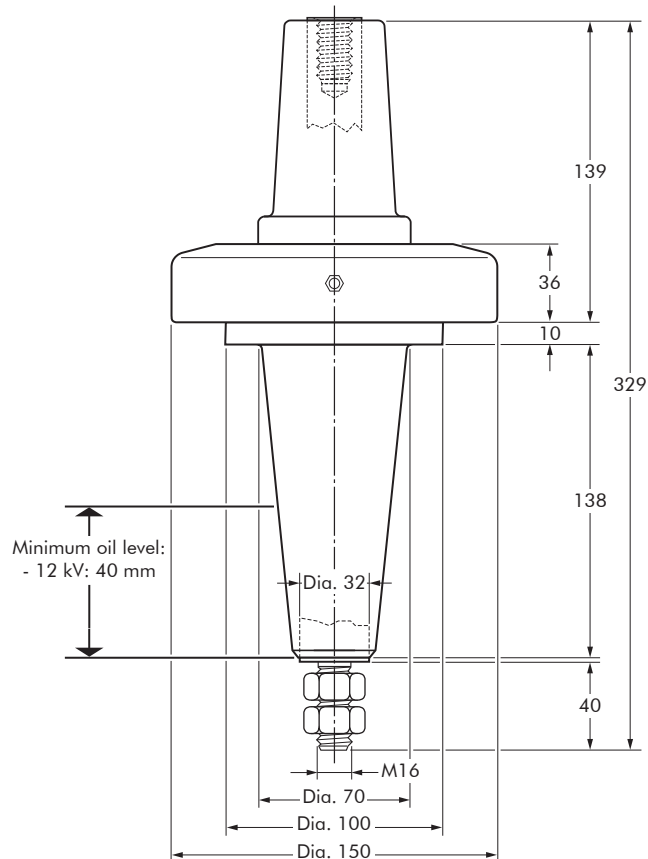

In mm.

| Equipment bushing type | Voltage U _o /U (kV) | Current I _r (A) |
|------------------------|--------------------------------|----------------------------|
| K400AR-4-ATEX | 6,35/11 | 1250 |

05/2013

K400AR-6-ATEX

INTERFACE C1

EQUIPMENT BUSHING

Up to 12 kV - 630 A

Application

For use in equipment insulated with oil fluid, typically for transformers, switchgear, capacitors...

Technical characteristics

- Each bushing is tested for AC withstand and partial discharge prior to leaving the factory.
- ATEX - Certification



Specifications and standards

The bolted type equipment bushings 400AR-6 are moulded epoxy insulated parts and meet the requirements of CENELEC EN 50180 and IEC 60137.

Certified for:

- II 2 G - Ex e IIC Gb and
- II 2 D - Ex tb IIIC Db IP6X

Ordering instructions

To order the equipment bushing, specify the type. The bushings can be supplied with an earth jumper (/J). This earth connection must be specified when ordering. E.g. K400AR-6/J-ATEX.

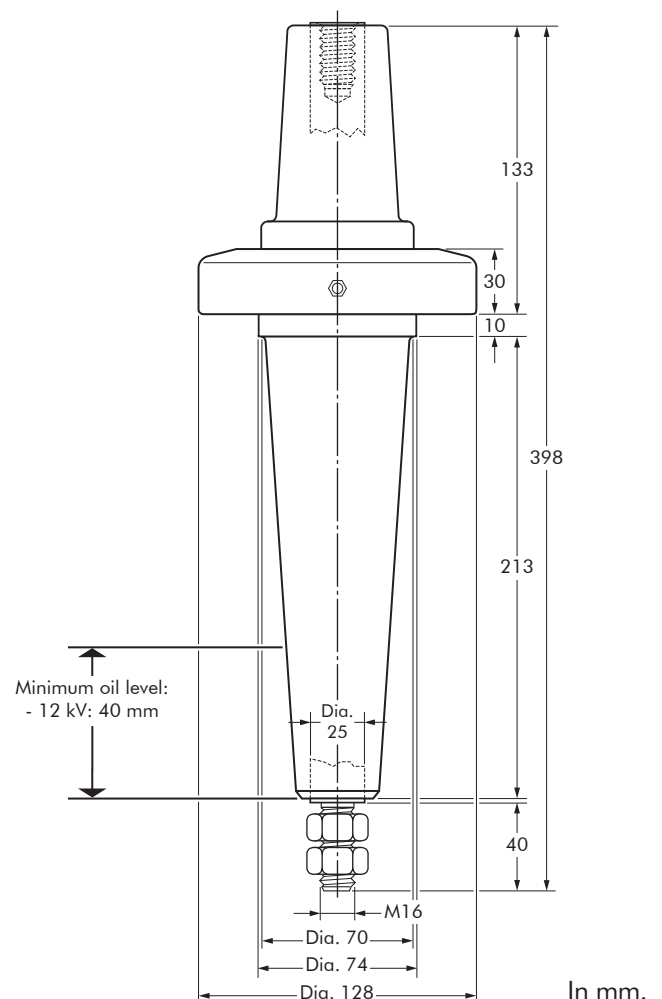

| Equipment bushing type | Voltage U_0/U (kV) | Current I_r (A) |
|------------------------|----------------------|-------------------|
| K400AR-6-ATEX | 6,35/11 | 630 |

400A-24B-ATEX INTERFACE C1 IN-AIR BUSHING

Up to 12 kV - 630 A

Application

For use in equipment insulated with air, typically for dry type transformers, motors, switchgear, capacitors...

Technical characteristics

- Each bushing is tested for AC withstand and partial discharge prior to leaving the factory.
- ATEX - Certification



Specifications and standards

The bolted type equipment bushings 400A-24B are moulded epoxy insulated parts and meet the requirements of CENELEC EN 50180, IEC 60071 and IEC 60137.

Certified for:

- II 2 G - Ex e IIC Gb and
- II 2 D - Ex tb IIIC Db IP6X

Ordering instructions

To order the equipment bushing, specify the type. The bushings are supplied with an earth jumper.

To include the ring clamp, add:

- /B, if per British standards
- /D, if per German standards
- /F, if per French standards.

E.g. 400A-24B/D-ATEX.

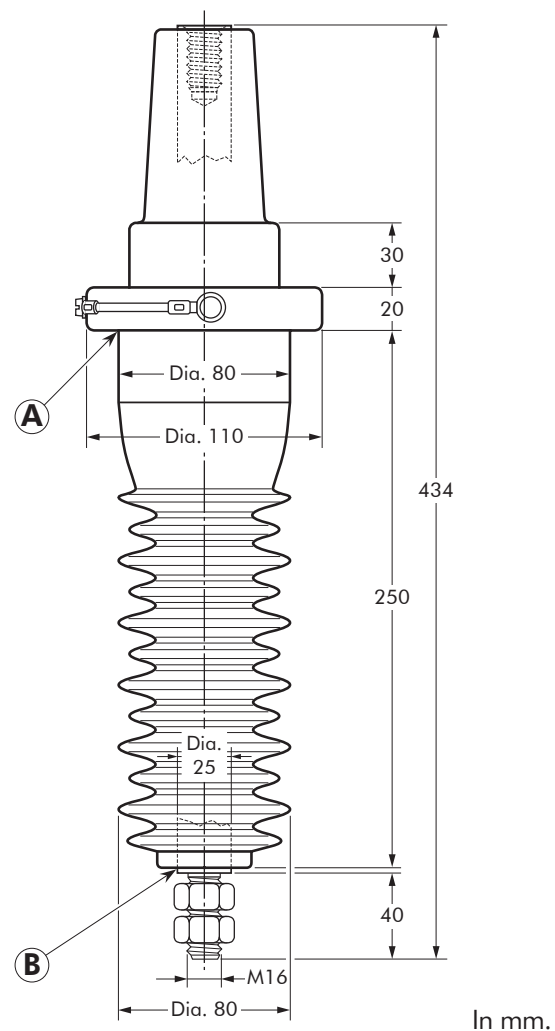

| Equipment bushing type | Voltage U_0/U (kV) | Current I_r (A) | Creepage distance A-B (mm) |
|------------------------|----------------------|-------------------|----------------------------|
| 400A-24B-ATEX | 6,35/11 | 630 | 500 |

05/2013

ACCESSORIES INTERFACE C

Up to 12 kV

Application

For use with connectors and bushings with an interface C as described by CENELEC EN 50180 and 50181.

Technical characteristics

- All these products, except the earthing plugs, are tested for AC withstand and partial discharge prior to leaving the factory.
- ATEX - Certification



400CP-SC Connecting plug

For connecting two or more connectors with a type C interface together, thus creating a separable cable joint or a multiple cable connection to equipment.

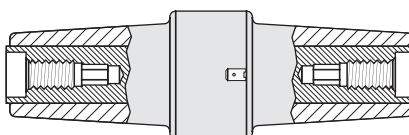

Ordering instructions

Order
K400CP-SC-ATEX for 12 kV.

440CP Connecting plug

For connecting two or more 440TB connectors, thus creating a separable cable joint or a multiple cable connection to equipment.

For use up to 1250 A.

Only for use with 440TB.

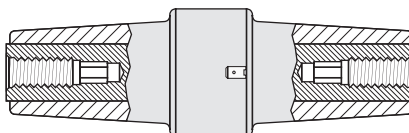

Ordering instructions

Order
K440CP-ATEX for 12 kV.

K676LRA/G-ATEX INTERFACE D TEE CONNECTOR

Up to 12 kV - 1250 A



6/10 (12) kV
6.35/11 (12) kV

Application

Separable tee connector designed to connect polymeric insulated cable to equipment (transformers, switchgear, motors...).

Also connects cable to cable, using the appropriate mating part.

Technical characteristics

- A thick conductive EPDM jacket provides a total safe to touch screen.
- Each separable connector is tested for AC withstand and partial discharge prior to leaving the factory.
- ATEX - Certification

Design

Separable connector comprising:

1. Conductive EPDM insert.
2. Conductive EPDM jacket.
3. Insulating EPDM layer moulded between the insert and the jacket.
4. Type D - 1250 A interface as described by CENELEC EN 50180 and 50181.
5. Conductor connector.
6. Basic insulating plug (with VD point).
7. Cable reducer.
8. Conductive rubber cap.
9. Threaded stud.
10. Earthing lead.

The screen break design enables cable outer sheath testing without removing or dismantling the connector.

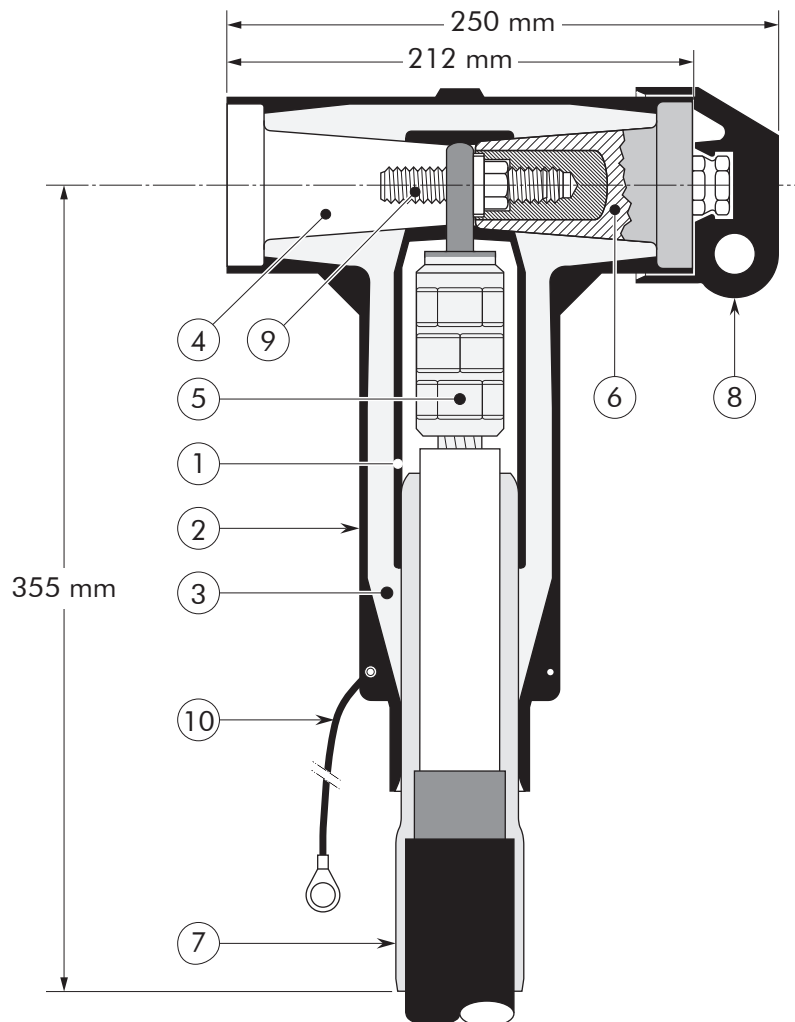

Specifications and standards

The separable connector 676LRA meets the requirements of CENELEC HD 629.1.

Certified for:

- II 2 G - Ex e IIC Gb and
- II 2 D - Ex tb IIIC Db IP6X

| Separable connector type | Voltage U_m (kV) | Current I_r (A) | Conductor sizes (mm ²) | |
|--------------------------|--------------------|-------------------|------------------------------------|------|
| | | | min. | max. |
| K676LRA/G-ATEX | 12 | 1250 | 50 | 630 |

05/2013

Kit contents

The complete K676LRA tee connector kit comprises the following components:

The kit also comprises lubricant, wipers, installation instructions and crimp chart.

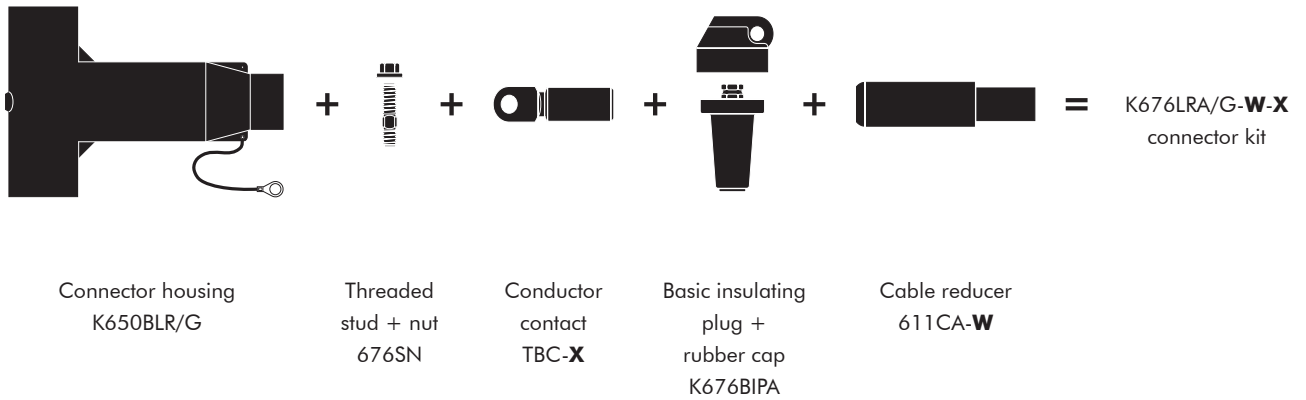

Ordering instructions





Select the part number which gives the best centring to the cable core insulation diameter.

Table W

| Ordering part number | Dia. over core insulation (mm) | |
|----------------------|--------------------------------|------|
| | min. | max. |
| K676LRA/G-15-X-ATEX | 16.0 | 22.0 |
| K676LRA/G-19-X-ATEX | 20.0 | 26.5 |
| K676LRA/G-22-X-ATEX | 23.5 | 31.0 |
| K676LRA/G-27-X-ATEX | 28.5 | 37.5 |
| K676LRA/G-32-X-ATEX | 34.0 | 42.5 |
| K676LRA/G-37-X-ATEX | 39.0 | 48.5 |
| K676LRA/G-43-X-ATEX | 45.5 | 56.0 |

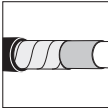
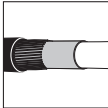
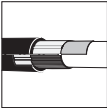
Table X

| Conductor sizes (mm ²) | Aluminium conductor | | Copper conductor |
|------------------------------------|---------------------|--------------|------------------|
| | DIN hexagonal | Deep indent | DIN hexagonal |
| 35 | 35(K)M-12-2 | 35KM-12-1 | 35(K)M-11-2 |
| 50 | 50(K)M-12-2 | 50(K)M-12-1 | 50(K)M-11-2 |
| 70 | 70(K)M-12-2 | 70(K)M-12-1 | 70(K)M-11-2 |
| 95 | 95(K)M-12-2 | 95(K)M-12-1 | 95(K)M-11-2 |
| 120 | 120(K)M-12-2 | 120(K)M-12-1 | 120(K)M-11-2 |
| 150 | 150(K)M-12-2 | 150(K)M-12-1 | 150(K)M-11-2 |
| 185 | 185(K)M-12-2 | 185(K)M-12-1 | 185(K)M-11-2 |
| 240 | 240(K)M-12-2 | 240(K)M-12-1 | 240(K)M-11-2 |
| 300 | 300(K)M-12-2 | 300(K)M-12-1 | 300(K)M-11-2 |
| 400 | 400(K)M-12-2 | 400(K)M-12-1 | 400(K)M-11-2 |
| 500 | 500(K)M-12-2 | 500(K)M-12-1 | 500(K)M-11-2 |
| 630 | - | 630(K)M-12-1 | 630(K)M-11-2 |

| | | | | | |
|---|---|---|---|---|---|
|  |  |  |  |  |  |
| For use with copper tape screened cables. Order: Kit MT. | For use with copper wire screened cables. No earthing device is necessary. | For use with Alupe or C 33-226 cables. Please contact our representative. | For use with other cable types. Please contact our representative. | For applications outdoors and in humid climate. Order: +MWS. | For use in potentially explosive atmospheres (for 12 kV max). Add -/ATEX to part number. |

K670AR-2-ATEX INTERFACE D EQUIPMENT BUSHING

Up to 12 kV - 1250 A

Application

For use in equipment insulated with oil fluid, typically for transformers, switchgear, capacitors...

Technical characteristics

- Each bushing is tested for AC withstand and partial discharge prior to leaving the factory.
- ATEX - Certification



Specifications and standards

The bolted type equipment bushings 670AR-2 are moulded epoxy insulated parts and meet the requirements of CENELEC EN 50180 and IEC 60137.

Certified for:

- II 2 G - Ex e IIC Gb and
- II 2 D - Ex tb IIIC Db IP6X

Ordering instructions

To order the equipment bushing, specify the type. The bushings can be supplied with an earth jumper (/J) or an earth plate (/GS). This earth connection must be specified when ordering.

E.g. K670AR-2/GS-ATEX.

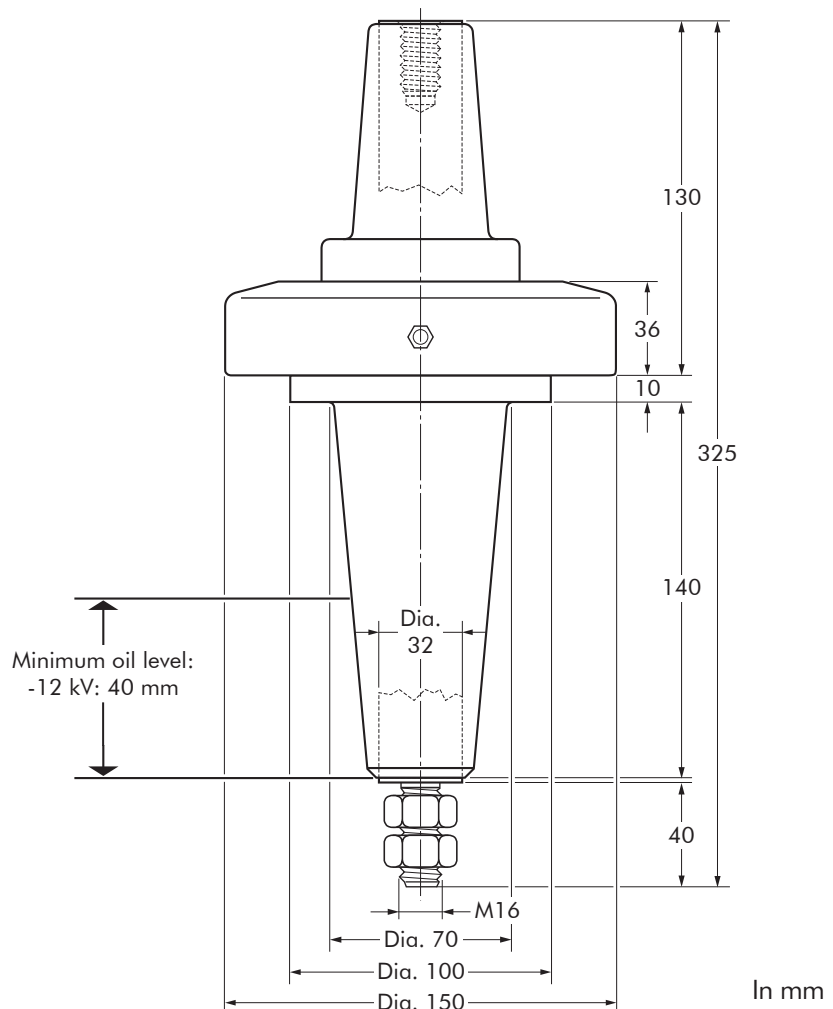

| Equipment bushing type | Voltage U_0/U (kV) | Current I_r (A) |
|------------------------|----------------------|-------------------|
| K670AR-2-ATEX | 6,35/11 | 1250 |

K672T1-ATEX INTERFACE D EQUIPMENT BUSHING

Up to 12 kV - 1250 A

Application

For use in equipment insulated with oil fluid, typically for transformers, switchgear, capacitors...

Technical characteristics

- Each bushing is tested for AC withstand and partial discharge prior to leaving the factory.
- ATEX - Certification



Design

The equipment bushing is a moulded epoxy insulated part in accordance with CENELEC EN 50180.

Specifications and standards

The bolted type equipment bushings 672T1 meet the requirements of IEC 60137.

Certified for:

- II 2 G - Ex e IIC Gb and
- II 2 D - Ex tb IIIC Db IP6X

Ordering instructions

To order the equipment bushing, specify the type.

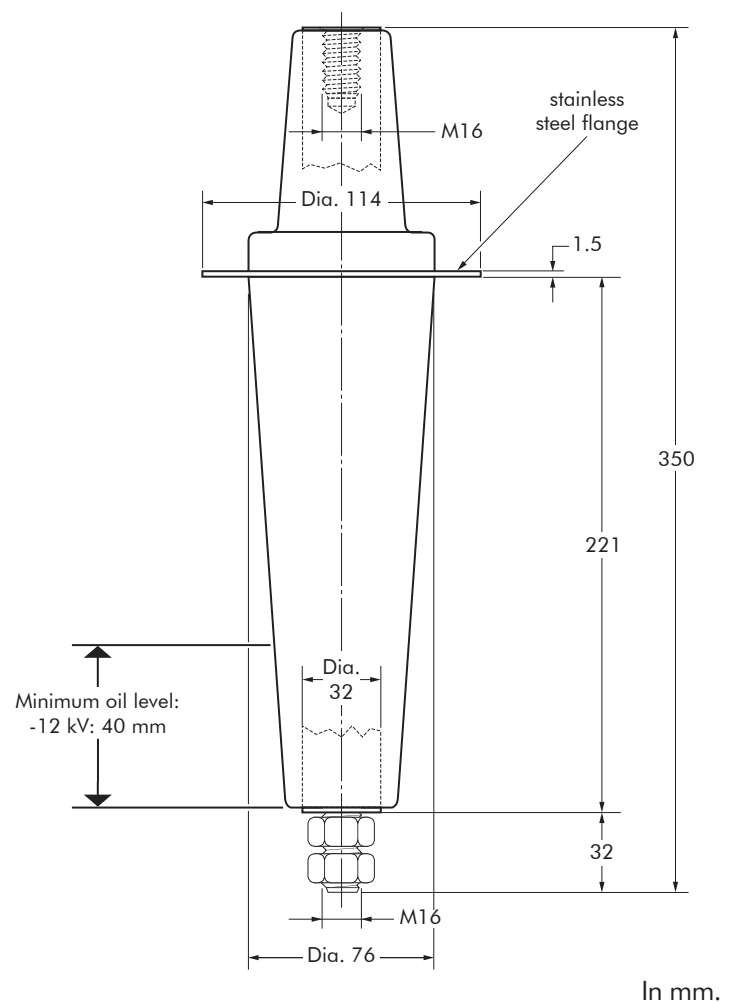

| Equipment bushing type | Voltage U_0/U (kV) | Current I_r (A) |
|------------------------|----------------------|-------------------|
| K672T1-ATEX | 6,35/11 | 1250 |

K672TBC-ATEX INTERFACE D EQUIPMENT BUSHING

Up to 12 kV - 1250 A

Application

For use in equipment insulated with air, typically for transformers, switchgear, capacitors...

Technical characteristics

- Each bushing is tested for AC withstand and partial discharge prior to leaving the factory.
- ATEX - Certification



Design

The equipment bushing is a moulded epoxy insulated part in accordance with CENELEC EN 50181.

Non-tracking insulating rubber boot and collars slip over the bushing shank.

Specifications and standards

The bolted type equipment bushings 672TBC meet the requirements of IEC 60137. Certified for:

- II 2 G - Ex e IIC Gb and
- II 2 D - Ex tb IIIC Db IP6X

Ordering instructions

To order the equipment bushing, specify the type.

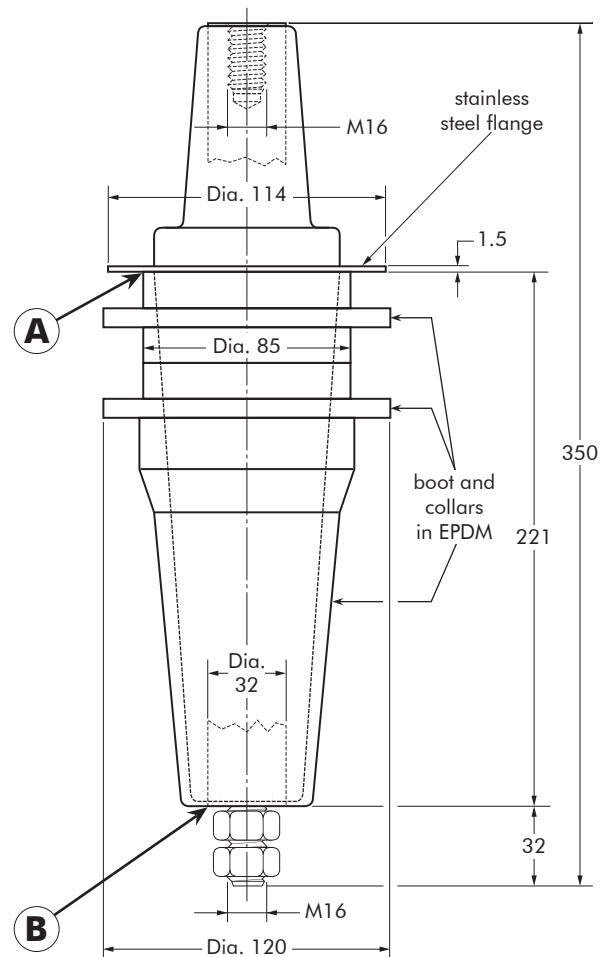

In mm.

| Equipment bushing type | Voltage U_0/U (kV) | Current I_r (A) | Creepage distance A-B (mm) |
|------------------------|----------------------|-------------------|----------------------------|
| K672TBC-ATEX | 6,35/11 | 1250 | 300 |

05/2013

ACCESSORIES INTERFACE D

Up to 12 kV

Application

For use with connectors and bushings with an interface D as described by CENELEC EN 50180 and 50181.

Technical characteristics

- All these products, except the earthing plug, are tested for AC withstand and partial discharge prior to leaving the factory.
- ATEX - Certification



675BE Bushings extender

Provides an extension piece to allow cables to stand away from equipment.

Is used in conjunction with the 680CP connecting plug.

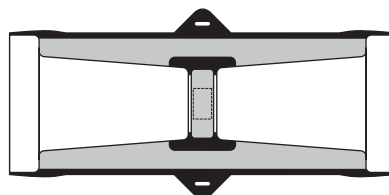

Ordering instructions

Order
K675BE-ATEX for 12 kV applications.

680CP Connecting plug

For connecting two or more connectors with a type D interface together, thus creating a separable cable joint or a multiple cable connection to equipment.

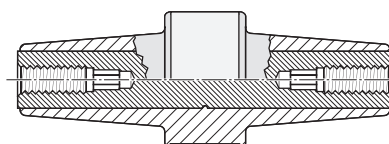

Ordering instructions

Order
K680CP-ATEX for 12 kV applications.

K944TB/G-ATEX INTERFACE F ASYMMETRICAL TEE CONNECTOR

**Up to 12 kV
Up to 2500 A**



**6/10 (12) kV
6.35/11 (12) kV**

Application

Separable tee shape connector designed to connect polymeric insulated cable to equipment (transformers, switchgear, motors, ...).

Also connects cable to cable when using the appropriate mating parts.

Technical characteristics

- The thick conductive EPDM jacket provides a total safe to touch screen which ensures safety for personnel.
- Each separable connector is tested for AC withstand and partial discharge prior to leaving the factory.
- ATEX - Certification

Design

Separable connector comprising:

1. Conductive EPDM insert.
2. Conductive EPDM jacket.
3. Insulating EPDM layer moulded between the insert and the jacket.
4. Type F interface as described by CENELEC EN 50180 and 50181.
5. Conductor connector.
6. Clamping screw.
7. Cable reducer.
8. Basic insulating plug (with VD point), type C interface as described by CENELEC EN 50180 and 50181.
9. Conductive rubber cap.
10. Earthing lead.

The screen break design enables cable outer sheath testing without removing or dismantling the connector.

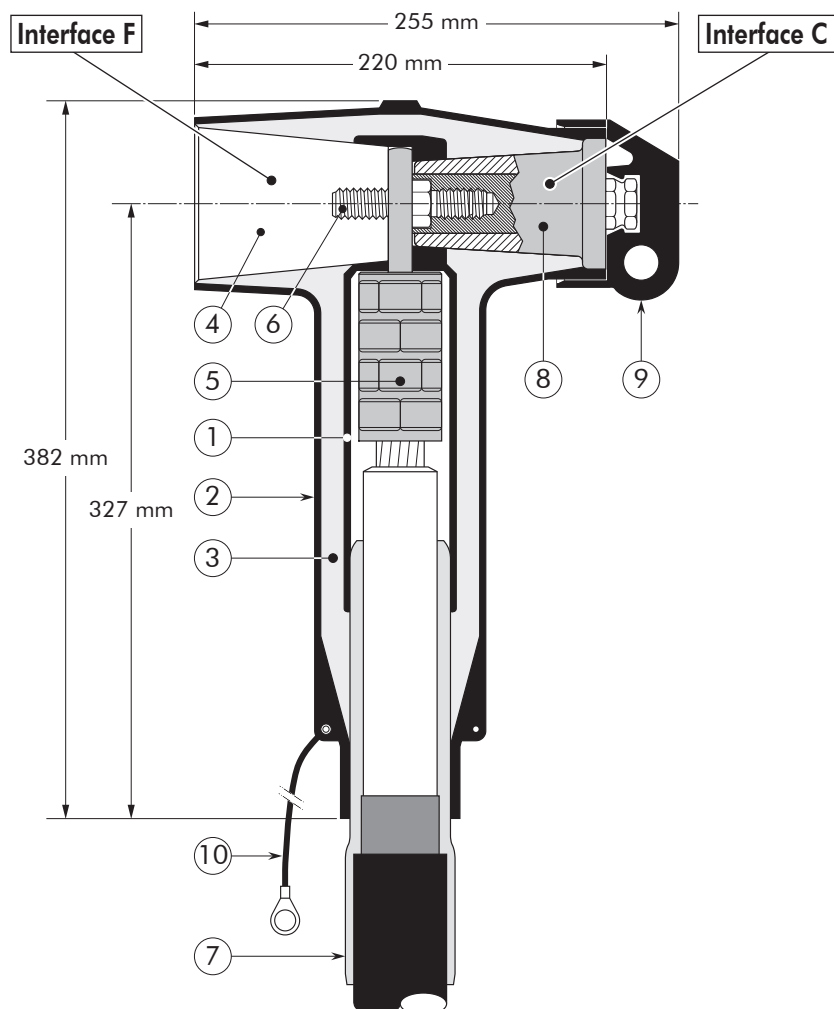

Specifications and standards

The 944TB/G separable connector meets the test requirements of CENELEC HD 629.1.

Certified for:

- II 2 G - Ex e IIC Gb and
- II 2 D - Ex tb IIC Db IP6X

| Separable connector type | Voltage U_m (kV) | Current I_r (A) | Conductor sizes (mm ²) | |
|--------------------------|--------------------|-------------------|------------------------------------|-----|
| | | | min | max |
| K944TB/G-ATEX | 12 | 2500 | 95 | 800 |

05/2013

Kit contents

The complete tee connector kit comprises the following components:

The kit also comprises lubricant, wipers, installation instructions and crimp chart.

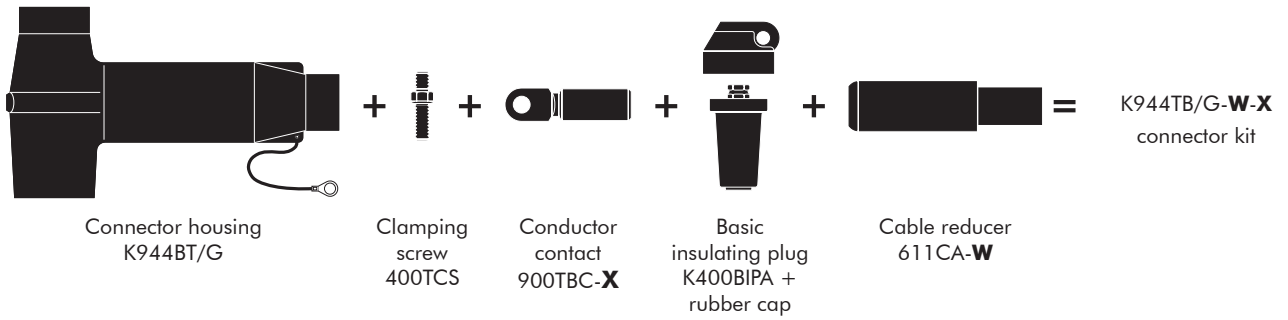

Ordering instructions

To order the tee connector, select the ordering part number which gives you the best centring of your core insulation diameter and substitute **X** using table X, according to your conductor size and type.

Table W

| Ordering part number | Dia. over core insulation (mm) | |
|-----------------------------|--------------------------------|------|
| | min | max |
| K944TB/G-15- X -ATEX | 16.0 | 22.0 |
| K944TB/G-19- X -ATEX | 20.0 | 26.5 |
| K944TB/G-22- X -ATEX | 23.5 | 31.0 |
| K944TB/G-27- X -ATEX | 28.5 | 37.5 |
| K944TB/G-32- X -ATEX | 34.0 | 42.5 |
| K944TB/G-37- X -ATEX | 39.0 | 48.5 |
| K944TB/G-43- X -ATEX | 45.5 | 56.0 |

Table X

| Conductor sizes (mm ²) | Aluminium conductor | | Copper conductor |
|------------------------------------|---------------------|--------------|------------------|
| | DIN hexagonal | Deep indent | DIN hexagonal |
| 95 | 95(K)M-12-2 | 95(K)M-12-1 | 95(K)M-11-2 |
| 120 | 120(K)M-12-2 | 120(K)M-12-1 | 120(K)M-11-2 |
| 150 | 150(K)M-12-2 | 150(K)M-12-1 | 150(K)M-11-2 |
| 185 | 185(K)M-12-2 | 185(K)M-12-1 | 185(K)M-11-2 |
| 240 | 240(K)M-12-2 | 240(K)M-12-1 | 240(K)M-11-2 |
| 300 | 300(K)M-12-2 | 300(K)M-12-1 | 300(K)M-11-2 |
| 400 | 400(K)M-12-2 | 400(K)M-12-1 | 400(K)M-11-2 |
| 500 | 500(K)M-12-2 | 500(K)M-12-1 | 500(K)M-11-2 |
| 630 | 630(K)M-12-2 | 630(K)M-12-1 | 630(K)M-11-2 |
| 800 | - | - | 800(K)M-11-2 |

| | | | | | |
|---|---|---|---|---|---|
| | | | | | |
| For use with copper tape screened cables. Order: Kit MT. | For use with copper wire screened cables. No earthing device is necessary. | For use with Alupec or C 33-226 cables. Please contact our representative. | For use with other cable types. Please contact our representative. | For applications outdoors and in humid climate. Order: +MWS. | For use in potentially explosive atmospheres (for 12 kV max). Add -/ATEX to part number. |

K900AR-1-ATEX / K900AR-2-ATEX K900AR-3-ATEX / K900AR-4-ATEX

INTERFACE F EQUIPMENT BUSHING

Application

For use in equipment, typically for transformers, switchgear, capacitors...

Technical characteristics

- Each bushing is tested for AC withstand and partial discharge prior to leaving the factory.
- ATEX - Certification

Up to 12 kV
Up to 2500 A



6/10 (12) kV
6.35/11 (12) kV

Specifications and standards

The bolted type equipment bushings 900AR-X are moulded epoxy insulated parts and meet the requirements of CENELEC EN 50180 and IEC 60137.

Certified for:

- II 2 G - Ex e IIC Gb and
- II 2 D - Ex tb IIIC Db IP6X

Ordering instructions

To order the equipment bushing, specify the type. The bushings can be supplied with an earth jumper (/J) or an earth plate (/GS). This earth connection must be specified when ordering.

E.g. K900AR-4/GS-ATEX.

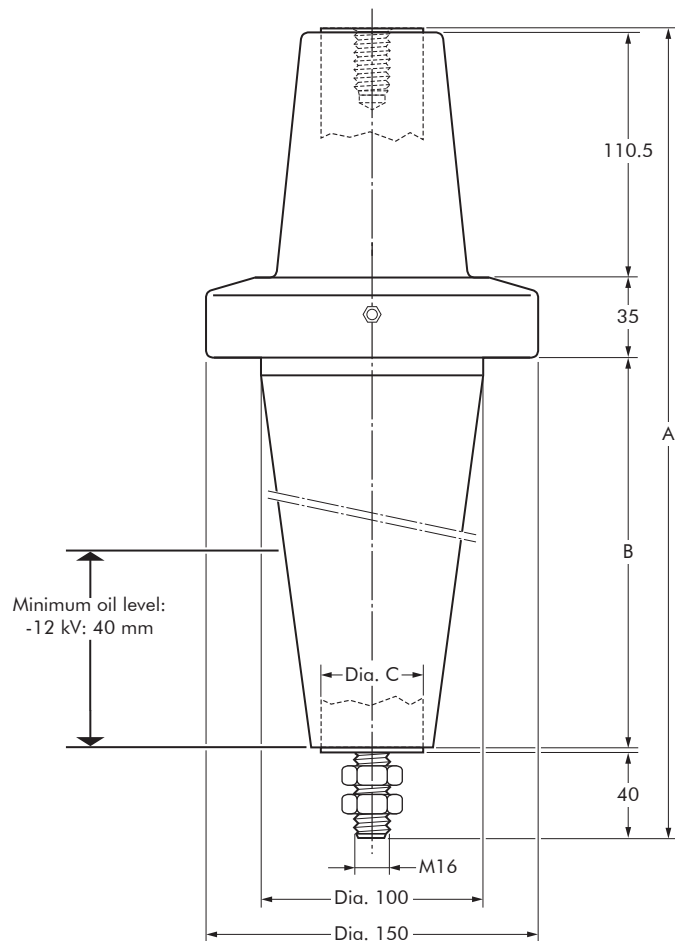

In mm.

| Equipment bushing type | Interface type | Voltage U_r (kV) | Current I_r (A) | Dimensions (mm) | | |
|------------------------|----------------|--------------------|-------------------|-----------------|-----|--------|
| | | | | A | B | Dia. C |
| K900AR-1-ATEX | F3 | 42 | 1250 | 364 | 175 | 32 |
| K900AR-2-ATEX | F2 | 42 | 630 | 364 | 175 | 25 |
| K900AR-3-ATEX | F1 | 36 | 2500 | 364 | 175 | 50 |
| K900AR-4-ATEX | F1 | 36 | 2500 | 259 | 70 | 50 |

05/2013



Additional catalogue information on power cable accessories
is available by contacting us at the address below.

Nexans Network Solutions N.V. - Div. Euromold • Zuid III, Industrielaan 12, B-9320 Erembodegem
Tel.: +32 (0)53 85 02 11 • Fax: +32 (0)53 83 10 13 • www.nexans.com • info.euromold@nexans.com

Catalogue also available on CD-ROM